

FENDT

CARAVAN



OPERATION GUIDE

CARAVAN

GB

2025



Dear Fendt Customer!

Thank you for purchasing a Fendt caravan, which will be your dependable companion for the most enjoyable days of the year for many years to come.

Thanks to our many years of experience in the construction of leisure vehicles we are able to react innovatively to current market conditions and demands.

Driving safety and comfortable living are, and have always been, indispensable elements of our product philosophy.

The name Fendt-Caravan has stood for high quality manufacturing for many decades now.

You will also be able to benefit from a dense network of dealer service points throughout Europe. Take advantage of your authorised dealer's experience and technical knowledge - we recommend speaking to him in detail before taking your first trip with your Fendt caravan.

Please read this manual carefully to ensure that you use your vehicle correctly.

Fendt's employees wish you many enjoyable trips and hope you will always have a safe journey with your new Fendt caravan.

Fendt-Caravan GmbH

1	Introduction	
1.1	General information.....	1
1.2	Markings in these operation instructions.....	1
2	Safety	
2.1	General information.....	3
2.2	Before the drive.....	5
2.3	Loading.....	6
2.4	Handling Performance.....	8
2.5	After the drive.....	9
3	Undercarriage and vehicle registration	
3.1	General information.....	11
3.2	Safety coupling AKS 3004.....	12
3.3	Locking brake facilitiesng und Radbremsen.....	13
3.4	Overrunning equipment and wheel brakes.....	13
3.5	AL-KO Trailer Control (ATC).....	15
3.6	Rotating stanchions.....	15
3.7	Vehicle registration.....	16
3.8	General inspection.....	16
3.9	Fit for a Speed of 100 km/h.....	17
3.10	Definition of mass.....	17
4	Wheels, tires	
4.1	Tires.....	19
4.2	Tire pressure.....	19
4.3	Profile depth and age of tires.....	20
4.4	Rims.....	20
4.5	Changing the tire.....	22
5	Exterior structure	
5.1	Ventilation and De-aerating.....	24
5.2	External entry.....	25
5.3	Service flap.....	29
5.4	Toilet flap.....	30
5.5	Gas-bottle container flap.....	30
5.6	Roof and roof rail.....	31
5.7	Guide rail for outer tent.....	31
5.8	Bicycle carrier.....	32
5.9	Subsequent installation of an awning.....	32
6	Interior structure	
6.1	Doors, flaps, drawers and kitchen worktop.....	33
6.2	Converting the seating arrangement into a bed.....	34
6.3	Bunk beds.....	38
6.3.1	Bunk beds in models with rear flap/rear external storage locker.....	38
6.4	Windows.....	40
6.5	Roof bonnets.....	40
7	Installation of electrical devices	
7.1	Safety tips.....	41
7.2	Electrical supply.....	41
7.3	Controls, switches, sockets in the kitchen unit.....	45
7.4	Lighting control system with switch/touch panel / Bluetooth control.....	46
7.5	Power supply using the LiFe battery package.....	65
7.6	Circuit diagram for lighting in the vehicle.....	71
7.7	Lights in the caravan requiring extra switching.....	73
7.8	Electrical floor temperature control system.....	74

7.9	Microwave.....	76
7.10	Air conditioning.....	77
7.11	Multimedia.....	77
7.12	Prewiring for antenna.....	77
8	Water	
8.1	Water supply.....	78
8.2	Warm water supply via Truma-Therme.....	79
8.3	Water taps.....	81
8.4	Cassette toilet.....	82
9	Gas	
9.1	General safety rules for the use of liquid gas facilities.....	83
9.2	Gas supply.....	85
9.3	Hot-air heating.....	86
9.4	Refrigerator.....	91
9.5	Gas cooker.....	93
9.6	Oven.....	93
10	Accessories	94
11	Maintenance and upkeep	
11.1	Maintenance.....	95
11.2	Ventilation.....	96
11.3	Upkeep.....	97
11.4	Winter operation.....	103
12	Waste disposal and environmental protection	
12.1	The environment and mobile travel.....	106
13	Technical data	
13.1	Tire pressure values.....	108
13.2	Technical data.....	109
13.3	Measurements of Outer Tent Perimeter.....	111
13.4	Basic equipment.....	113
13.5	Lighting.....	114
Index	117

1.1 General information

Our caravans are continuously being further developed. Please understand that we reserve the right to make changes to their equipment, shape and technology. Therefore, Fendt shall not be liable for any claims arising from the contents of this handbook. The equipment used at the time of printing is described in this handbook and should be transferred accordingly to the layouts of all the different caravan variations.

Please understand that we cannot describe all of the individual variations. Your dealer will be pleased to answer any special questions regarding the equipment and technology of your caravan. Check our website **www.fendt-caravan.com** to find the Fendt caravan dealer or service partner closest to you.

Your Fendt caravan has been built in accordance with the latest technology and recognised safety regulations. This vehicle conforms to the EN 1645-1 standard.

Despite all of these safety measures, it is possible that people may be hurt or the caravan damaged if the safety instructions in this handbook and the warnings posted on adhesive labels in the caravan are not followed.



If technical changes or additions are subsequently carried out by third parties unknown to us, the vehicle's operating licence may expire. Fendt-Caravan GmbH cannot be held liable for any damages caused in this manner.

Before the first trip

You should certainly familiarize yourself thoroughly with the contents of this handbook; it is much more than a reference book.

1.2 Markings in these operation instructions

The handbook explains the caravan as follows:

Texts and illustrations

The texts which accompany illustrations are found directly to the right of the illustrations.

Details in illustrations (here: entry door) are marked with position numbers ①.

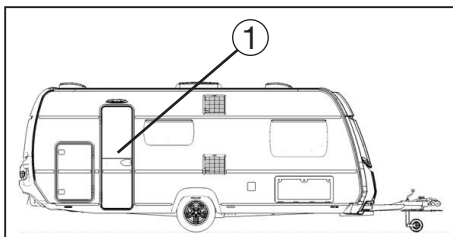

Marking of details using position numbers

Pictures may vary somewhat from the equipment in your caravan.

Lists

- Lists are based on key points and are preceded by a dash.

Procedural guidelines

• Procedural guidelines are also based on key points and begin with a bullet point.

Guidelines



Guidelines point out important details which ensure the trouble-free function of the caravan and its equipment. Please bear in mind that various models have different equipment; therefore, varying descriptions are possible.

Warnings



Warnings point out dangers which, if they are not followed, could cause damage to equipment and/or injury to persons.

Environmental tips



Environmental tips show possible ways to reduce strain on the environment.

2.1 General information

Keys

The following keys are provided with the caravan:

- Two keys which fit into the following locks:
 - entry door,
 - service flaps,
 - toilet flap.
- gas-bottle container lid
- fresh-water tank lid



Warnings and information labels are attached both inside and outside the vehicle. These are meant for your safety and may not be removed.

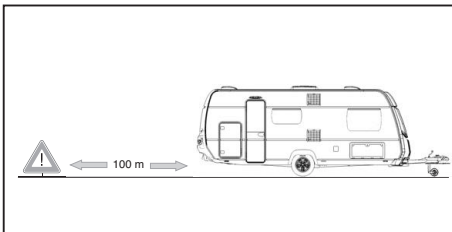

Please observe the regulations of the country you are travelling in regarding the minimum distance between the warning triangle and the trailer.

Emergency equipment

To be prepared for an emergency, you need at least three basic items of rescue equipment (first aid kit, warning triangle and fire extinguisher) which you should carry at all times and know how to use.

- first aid kit
- warning triangle
- high-visibility vest

Fire prevention measures

- Never leave children unattended in the vehicle.
- Keep flammable materials away from all heating and cooking appliances.
- Changes to the electrical system, gas system or built-in devices may only be carried out by professional, authorised workshops.
- Place a fire extinguisher at the main entry door.
- Ensure that everyone is familiar with the guidelines on the fire extinguisher.
- Place a fire cover near the gas cooker.
- Keep all escape routes clear.
- Ensure that everyone is familiar with the fire prevention measures on site.

Fighting a fire

- Evacuate all passengers immediately.
- Close the main shut-off valve on the gasbottle as well as the shut-off valves on gaspowered appliances.
- Shut off the electrical supply
- Sound alarm and call the fire department.
- Only fight the fire yourself if this is possible without risk.



Smoke detector

The base for the smoke detector has already been installed in a suitable place on the ceiling. To operate it, put the battery in (making sure that plus and minus are in the right direction) and fasten the smoke detector to the base by turning it. The system has been fitted with a safety feature. If there is no battery or the battery has not been put in correctly, the smoke detector will not fit into the holding clamp. Test the device regularly (we recommend once a week) or whenever you first use the caravan after it has been unused for a longer period of time, following the procedure described under 'Test'.



Please observe the manufacture's operating instructions.

Test

Press the test button for at least 4 seconds until the alarm goes off. This will activate a self-test program. The alarm goes off when the electronic system (horn and battery) is working.

Exchanging the battery

Energy for the smoke detector system is provided by a 9-volt battery. The system will not work without a battery. Insert a new battery, ensuring it is the correct type, when you hear the battery's warning signal (a „peeping“ sound, easily heard, that is repeated every 30-40 seconds for approx. 7 days).

Evacuation plan

Hold a meeting with your family to discuss the possibilities for evacuating the caravan. Everyone who uses the caravan should know what to do in case fire breaks out.

What to do when the alarm goes off?

Leave the caravan immediately, either through the door or a window, depending on where the fire has broken out, following the evacuation plan you have discussed. Every second counts! Do not waste any time getting dressed or packing your valuables, etc. As soon as you are outside the caravan, keep moving until you are a safe distance away from it. Notify the fire department immediately from a neighbour's telephone or use your cell phone. Do not, under any circumstances, go back inside the burning caravan. Shout loudly to warn any neighbouring caravans parked within the safety zone. Do not enter the caravan until the fire department has given you permission to do so.

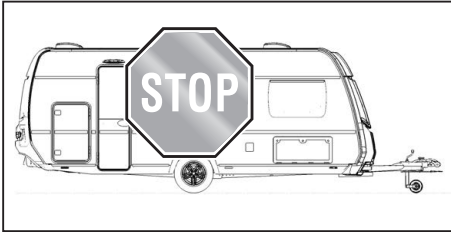

A smoke detector will not prevent fires or put them out. If it is working properly, it will merely provide you with those possibly decisive seconds to save yourself and notify emergency services.

2.2 Before the drive

As the owner and driver, you are responsible for the condition of your vehicle. Therefore, you must note the following points:

Exterior

Go around the carriage and prepare for the drive as follows:

Preparation of the vehicle

- The caravan must be hitched properly (see guidelines for the safety hitch AKS3004).
- Release the handbrake for the caravan and place the contact-breaking cable around the ball neck of the permanently attached tow coupling. If the tow coupling is detachable, the contact-breaking cable must be hooked into the eyelet provided on towing bracket for that purpose.



Please note that in some countries the safety line must be attached to an eyelet or bracket that is securely mounted on the car. In these countries, it is not sufficient to simply wrap it around the ball neck. Doing so will be penalised by an administrative fine. Please inform yourself in good time before beginning your journey about the legal regulations in the countries you plan on driving through.



- Tighten the tire bolts after driving the first 50 km.
- Plug the 13-channel plug in the socket of the base vehicle.
- Inspect the vehicle lighting.
- Turn the winding stanchions up.
- Turn the front landing wheel up into its correct position (**see picture**), then lock and secure it. This must not interfere with the function of the brake linkage or the contact-breaking cable.
- Turn off the gas bottles and secure them (**heating is forbidden while driving**) **Exception:** using a licensed gas flow monitor (e.g. Truma-Duo-Control CS)
- Empty the waste water tank.
- Close gas bottle compartment.
- Adjust outer mirrors on base vehicle.
- Check caravan's tire pressure (see tire pressure table).
- Close all windows.
- Close the service flaps.
- Close and firmly lock roof bonnet.
- Shut off the light on the outer tent.
- Close and secure entry door.
- If necessary, pull the electrical cord to the 230 V mains supply out of the exterior socket.
- If necessary, pull the television antenna inward as far as possible or fold over the satellite dish.
- If necessary, secure all bicycles and lash them to prevent slip page, ensuring that they do not cover any lighting equipment.
- In winter, the roof must be free of snow and ice before you begin to drive.



Post a list with all significant weights and measurements of the carriage in a highly visible place in the base vehicle.

Interior

You must also prepare the interior of the vehicle.

Preparing the interior

- Sort all loose objects and store them in their respective compartments.
- Heavy and/or voluminous objects (e.g. TV/ radio) should be stored safely and secured against slipping.
- If necessary, redirect refrigerator to 12-volt operation.
- Shut off all interior lighting.
- Ensure that all fluids, including those in refrigerator, are secured to prevent leakage.
- Close main valve on gas container and quick-close valves on all gas-powered appliances.
- Close all doors (incl. refrigerator door), drawers and flaps tightly.
- Latch the sliding door.
- Lower table and secure it.



Staying in the caravan during the drive is prohibited by law!

2.3 Loading

Rules for loading

- Spread the load evenly between the left and right-hand side of the caravan. Heavy or bulky objects belong in the lower storage compartments and near the axle.
- If your caravan has a tandem axle: distribute the centre of weight between the two axles.
- Never focus the load in the caravan to the rear (danger of swinging back and forth).
- Heavy objects should be stowed securely to prevent them from slipping.
- Lighter objects (clothing) should be stowed in the wall cupboards.
- You may not always be able to follow the recommended stowing arrangement, because storage possibilities are distributed throughout the entire interior of the caravan. If necessary, stow heavy objects in the base vehicle.
- Store baggage in the interior in cupboards and storage compartments.
- Secure doors and flaps.
- After loading, check total weight and axle load(s) at a public weigh station.



Maximum loading of 10 kg per running metre wall cabinet/drawer/lower kitchen cabinet.
Maximum loading of 10 kg per cubic metre wardrobe/storage box underneath the bed/storage box in the seat chest.



The gross vehicle weight rating indicated in the vehicle documents as well as the permitted drawbar load may not be exceeded. Also note the permissible drawbar load of your base vehicle.

Providing your base vehicle permits this and depending on the size of the caravan, you can improve the driving quality by increasing the drawbar load.



The max. permissible load for the left and right wheels each equals half the value (for a single axle) and onequarter of the value (for vehicles with a tandem axle) respectively of the technically max. permissible maximum weight.



The lower a vehicle's centre of gravity is, the better its performance in curves and on the road.

Stowage areas in the caravan

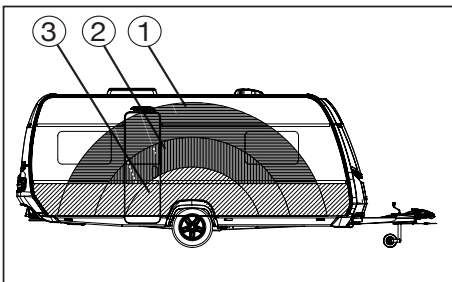

- Light objects ① such as towels and lightweight laundry.
- Medium-weight objects ② such as clothing, laundry and food.
- Heavy objects ③ such as the outer tent, boat motor or crates of drinks.

If the caravan has been fitted with a bicycle carrier on the drawbar, the increase in the drawbar load caused by the weight of the bicycles must be counterbalanced by the rest of the load.

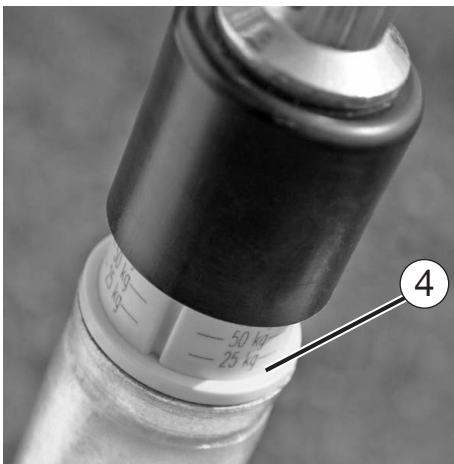

* model/series-specific

Drawbar load

You will only achieve optimum driving stability and decisively increase your safety on the road if the drawbar load has been properly adjusted for your combination of base vehicle and the caravan being pulled. The drawbar load indicates the power the caravan's drawbar exerts on the car's clutch.

Rules for the drawbar load

- Set the drawbar load correctly! You can, for example, use normal bathroom scales: use a strip of wood (approx. 400 mm long) to position them vertically under the coupling jaw. It may also be possible to roughly estimate the drawbar load by means of the drawbar load scales* ④ integrated in the front landing wheel, whereby the drawbar of the caravan must be in a horizontal position.
- Always check the drawbar load before you start to drive!
- The specified drawbar load (see handbook or type plate) and the permissible overall mass of the base vehicle and the caravan may not be exceeded!

How to adjust the correct drawbar load:

1. Determine the maximum drawbar load of your base vehicle by checking its documentation, the type plate or the drawbar plate.
2. **Your Fendt caravan has a maximum permissible drawbar load of 100 kg.**
3. Adjust the drawbar load on the caravan to the lower of the two values by loading it carefully. At the same time, try to make full use of this value.
4. The lower of the two specified values for the drawbar load, i.e. that of the base vehicle or the caravan, may not be exceeded.

2.4 Handling Performance Driving

Take a test drive or a safety training course before the first long drive to better acquaint yourself with the carriage in driving conditions.

Rules for driving

- Do not underestimate the length of the carriage.
- Exercise special caution when driving toward yards and through gates.
- In conditions with strong side winds, slick ice or wet roads, the carriage could move back and forth.
- Adjust driving speed to overall street and traffic conditions.
- Long, lightly sloping roads are potentially dangerous. Measure your speed from the outset in such a manner that the carriage can be accelerated, if necessary, without endangering other drivers or pedestrians.
- If the carriage moves back and forth on a sloping road, brake carefully but rapidly if the carriage forms a line, i.e. if it is stretched.
- **Never** increase speed if the carriage becomes pendulous.
- Do not drive down a hill any faster than you would drive up one.
- When overtaking or being overtaken by trucks or buses, the carriage can be caught up in air suction. This may cause the carriage to swerve or fishtail.

Driving around curves

Your carriage is considerably longer than a car.

Rules for driving around curves

- Do not take curves too quickly or too sharply!
- Take the curve at a somewhat wider radius when turning.
- Note that the caravan can sheer out of line over the rear.



Please note that by installing a bicycle carrier on the drawbar you may reduce the steering angle between the car and the caravan.

Brakes

A trailer carriage behaves differently from an individual vehicle while braking. Therefore, it is advisable (especially for inexperienced drivers) to conduct several braking tests on a suitable surface. The braking distance for a carriage is longer than that of an individual vehicle. The load in the caravan also has a significant influence on the braking distance.

Rules for braking

- Note the longer braking distance on wet roads.
- When driving down mountains or steep hills, do not use a higher gear than when driving uphill.
- Principally, an overrunning brake system cannot differentiate between a "normal" braking procedure and driving over a pass, which lasts for a longer period of time. This can cause the wheel brakes to heat up strongly so that, if necessary, you must give them sufficient time to cool down.



Due to the design of the brakes, there may be increased wear in the brake lining during the initial break-in phase. We recommend that, after you have driven approx. 500 km, you have the basic setting for the brakes checked by a specialist company and adjusted if necessary (**Initial inspection**).

Not applicable for brakes with automatic adjustment (e.g. **AL-KO-AAAPremium Brake**).

Driving in reverse

Your Fendt caravan has a braking system with automatic reverse. This makes driving in reverse possible without activating the overrunning brake. However, in addition to rolling resistance, the residual brake force must first be overcome.

The next time the caravan moves forward the braking system will work normally again.

Rules for driving in reverse

- The caravan tilts in the opposite direction in which you steer.
- Have someone provide assistance when driving in reverse.

Shunting

Your carriage is significantly larger than a car.

Rules for shunting

- There is a significant blind spot in shunting, even when the exterior mirrors are properly adjusted.
- Use a guide when turning into difficult parking spots.



When positioning the caravan manually, only use the steering handles at the front and rear ends of the caravan. Never push on the plastic parts or the walls.

2.5 After the drive

Choosing a parking place

Rules for choosing a parking place

- The parking place should be as horizontal as possible.
- Check to see that the entry step is positioned horizontally (important for refrigerator function).
- Balance the lengthwise slant with the front landing wheel.
- Balance the crosswise slant by laying appropriate boards or a ramp under a wheel.



Do not compensate differences in height with the lift stanchions.

Securing the vehicle

Rules for securing the vehicle:

- Set the parking brake.
- Only extend the rotating stanchions as far as necessary so that the axle still bears part of the weight. (The crank is clipped to the bottom of the gas-bottle container.)
- Lay mats under the lifting stanchions when on soft ground.
- Use stop-blocks to secure the wheels.

Redirecting electrical devices

Rules for redirecting electrical devices

- Open the main shut-off valve on the gasbottle as well as the shut-off valves on the gas-powered appliances you require.
- Redirect the refrigerator from 12V to gas or 230V; otherwise, the battery of the base vehicle could be depleted.

Water installation

Water left standing in the fresh water tank or the pipes quickly becomes undrinkable.

Therefore, check the water pipes and the freshwater tank after each use to ensure they are clean. If necessary, use chemical or biological disinfectants and rinse well with sufficient fresh water.

3.1 General information

Frame parts and axles are components of the undercarriage. No technical modifications are allowed; otherwise, the terms of operation are no longer valid!



Technical modifications are only possible after the manufacturer has given his consent.

For the sake of traffic safety, the vehicle undercarriage must be maintained just as conscientiously as the base vehicle itself. This maintenance should be carried out by your Fendt dealer. If spare parts are required, use only the original parts designated by the manufacturer.



Generally, caravans are not suitable for pulling by lorries or buses. If this is done permanently, they will be damaged.

Greasing and oiling

Regularly examine and grease the sliding parts and stationary parts of the undercarriage. If the caravan is used seldom, yearly maintenance is required.

Overrun coupling for greasing and oiling

- Grease the tie rod around the gangway bellows
- Grease the bearing screws on the pivot arm and the brake lever above the lubricating nipple
- Grease the joint of the joint head
- Oil the joints of the spring brake on the brake lever

Recommended lubricant

multi-purpose grease in accordance with DIN 51825 KP2 G 30



Maintenance and adjustments to the brake system may only be carried out by an authorised specialist company!



You can find further guidelines in the operating instructions from the axle supplier.

3.2 Safety coupling AKS 3004



The caravan is equipped with an anti-rolling coupling in accordance with ISO 11555-1. This safety coupling stabilises the caravan while driving and ensures better driving performance.



WARNING: The laws of physics cannot be defied with a safety hitch. If the limits (of speed and weight conditions) are exceeded, traction and cornering force are reduced, which then becomes the responsibility of the driver. Therefore, avoid elevated risks. Please take note of the permitted drawbar load for your base vehicle.

Use the drawbar load scales on the front landing wheel to determine the current value of the drawbar load of the caravan.



Please observe the manufacture's operating instructions (enclosed).

Noises while driving

Generally, the friction pads of the AKS 3004 do not make noises! Any clicking, creaking and screeching noises could be caused by the following

- foreign matter or dirt between the friction pad and the drawbar ball
- dry operation of the drawbar/tie rod in the bushings of the overrun coupling
- drawbar ball on the base vehicle can be removed and there is too much tolerance in the lock mechanism
- surface coating has not been removed from drawbar ball (grease, galvanised, Dacomet, varnish, KTL or any other coating)

To eliminate

- Clean the drawbar ball and the friction pads by lighting sanding the pads with sandpaper (grain: 100-120).
- Use the lubricating nipple to grease the bushings. In addition, pull the gangway bellows on the overrun coupling off towards the front and grease all of the exposed drawbar.
- Lubricant: multi-purpose grease in accordance with DIN 51 825.
- Take the caravan to an authorised specialist company. Have the contact surfaces checked for damages and the lock mechanism checked that it is functioning correctly. If necessary, replace the drawbar ball or, if permitted, regrease the lock mechanism (please refer also to the operating manual for the removable drawbar ball).

3.3 Locking brake facilities

The components of the brake facilities, particularly the overrunning equipment, wheel brakes and towbar were checked in accordance with the appropriate EU Guidelines and may only be used in a licensed combination.

If you alter or modify any components of the brake facilities, the operation permission loses its validity. Modifications may only be made with the manufacturer's permission.



Parking the carriage

When parking the carriage, the locking brake of the caravan must be activated.

To lock

- Pull the locking brake lever upward by the handle ① until it locks into place. The locking brake lever is pressed into the final position by the gas pressure spring.

To release

- Press the locking brake lever back into the original position.

3.4 Overrunning equipment and wheel brakes

Overrun coupling



We recommend that you always check this is functioning correctly before using the caravan.

a) Hand brake

- Pull the hand brake lever and check that it has room to move freely
- Check the condition of the pneumatic spring
- Check the condition of the spring brake

b) Support wheel and immobilizing handle

- Check wheel for damages
- Release immobilizing handle and check screw thread
- Push support wheel up and down
- Pull immobilizing handle tight
- Use crank to crank the support wheel out and in again

c) Tie rod bearing

- Pull out the tie rod as far as it will go
- Press the tie rod up and down - maximum tolerance: +/- 0.3 mm (only for Euro-AE)

d) Mounting bolts for overrun coupling and coupling

- Check that all mounting bolts for the overrun coupling and the coupling have been pulled tight.

e) Contact-breaking cable

- Check the ring of the contact-breaking cable, located on the hand brake lever
- Check the condition of the cable guide
- Check the condition of the snap hook
- Check the condition of the cable

Brakes

The brake linings are wear and tear parts. Therefore, their condition must be checked at least every 10,000 km, but no later than once every year. If the overrun travel of the drawbar is significantly increased, it is necessary to adjust it sooner. This is often caused by heavy use: the technically permissible maximum weight is utilised 100% and/or frequent uphill drives.



- When driving downhill on a mountain pass, check to ensure that the brakes are cooled sufficiently.
- Put the base vehicle into a lower gear and drive downhill at slow speed.
- Stretch the trailer combination as often as possible to avoid continuous buffing by the caravan.
- Always make use of parking areas and passing points to give the brakes a chance to cool off.



Please read the separately enclosed operating manual of the axle/brake manufacturer.

Planned maintenance intervals



Allow only authorised companies to work on the brake system of your caravan. The documents provided with your vehicle also include a list of the axle/brake manufacturer's service stations.

If maintenance is not carried out at regular intervals as specified, this may result in increased brake wear or a malfunction that could lead to a complete failure of the wheel brakes.

Brakes should be checked for the first time or basic maintenance should be carried out after driving 500 km, but no later than after the first six months, depending on which event occurs first!

- Check the brakes and adjust them if necessary



Not applicable for brakes with automatic adjustment (e.g. AL-KO-AAAPremium Brake)

Check the brakes every 5,000 km or 12 months

- Check the brakes; if necessary, replace the brake pads.
- Adjust the brake pads.

Service the brakes every 10,000 km or 24 months

- Major brake inspection according to manufacturer's specifications.

Here is a brief summary of the most important aspects to ensure that the caravan's brakes operate safely:

- Ensure that the maximum load is not exceeded.
- It is imperative that the caravan and its components are handled carefully and in a professional manner.
- The brakes can only function correctly if maintenance and up-keep are carried out on a regular basis.



The AAA Premium Brakes are not self-cleaning, nor are they maintenance free!
Maintenance intervals must be observed!
These intervals are reduced if the brakes are subjected to heavy loads.

3.5 AL-KO Trailer Control (ATC) (optional extra)

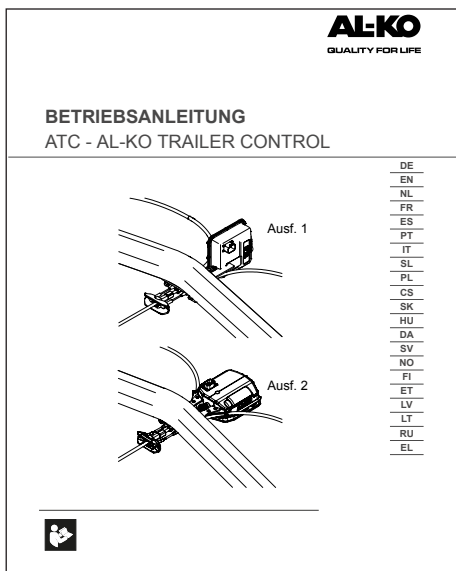

AL-KO Trailer Control (ATC) recognises if the trailer starts to swing too much, beyond the acceptable limits, and reacts automatically. If necessary, the trailer will be braked automatically.



ATC is obtainable for various weight ranges and must be compatible with the permissible maximum weight of the caravan.



The limits imposed by the laws of physics cannot be suspended by ATC. The vehicle's speed must always be adjusted to take weather, road and traffic conditions into account.

Before driving:

1. Hitch up the trailer.
2. Plug in the 13-pin trailer cable to the tow vehicle.
3. Check the ATC's LED light.
 - ATC will start an auto-test - LED lights up red for approx. 3 seconds.
 - LED switches to green: the rig is now ready to drive.
4. Check the lights on the trailer.



In most cars, the automatic start-stop system will automatically be deactivated when towing. Should this not be the case, the automatic start-stop system must be manually deactivated. Otherwise, there may be conflicts in the device electronics.

Please refer also to the separately enclosed instructions for use and safety provided by the device manufacturer.

3.6 Rotating stanchions



The rotating stanchions are located in the front and rear under the caravan.

Turning the rotating stanchions outward

- Park the vehicle as horizontally as possible.
- On soft ground, lay a sturdy mat or suitably sized board under the rotating stanchions to prevent the caravan from sinking.
- Turn the rotating stanchions outward.



The rotating stanchions may only be used for support, and not for leveling out or raising.

Turning the rotating stanchions inward

- With the crank, turn the rotating stanchions inward to the horizontal position.

The crank for the rotating stanchions is located in the bottle container at the front; it is clipped into a holder.

3.7 Vehicle registration

Every vehicle which uses public roads is subject to registration. This includes your new caravan. You can register the caravan at your local registration office.

The following documents are required to initiate the registration process:

- motor vehicle registration certificate, Part II
- insurance card
- personal identification or proof of residence
- possibly, power of attorney to have someone else register the caravan

Please remember to apply for a suitable "100 km/h" sticker, should you require one.

3.8 General inspection

In accordance with Section 29 of German Road Traffic Licensing Regulations, your caravan must undergo a major inspection every two years. This major inspection may be carried out by the TÜV (Technical Inspection Authority), DEKRA Vehicle Inspections or another accredited technical support organisation.

The following documents must be presented at each inspection:

- motor vehicle registration certificate, Part I
- valid certificate of inspection for gas facilities, documenting installation. The initial certificate is located in the service package for the caravan. **(Please observe country-specific variants)**

Vehicle identification number

The 17-digit vehicle ID number is located:

- 1.) stamped on the longitudinal chassis beam in the direction of traffic, on the right-hand side in front of the tire
- 2.) on the manufacturer's type plate in the gas-bottle container.

Please have the vehicle ID number at hand in case of inquiries or when visiting your Fendt-Caravan dealer.

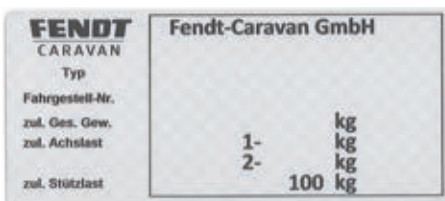

Manufacturer's type plate



Picture may vary somewhat from the actual model.

3.8 Fit for a Speed of 100 km/h

1. Your Fendt caravan is technically equipped for a maximum speed of 100 km/h. Under no circumstances may this speed be exceeded!
2. Note the permissible maximum speeds for trailer carriages in the country in which you are travelling!
3. Road traffic regulations in **Germany** were changed on 22 October 2005. Your caravan was already set to a speed of 100 at the factory, and this has been entered in the caravan's registration documents. Upon request, the 100 km/h sticker will be issued by the road traffic authority when the caravan is initially registered and attached to the back of the vehicle.
4. The following points must be observed, because you are responsible for adhering to them. If they are not met, the maximum speed for the caravan is no more than 80 km/h!
 - a) The base vehicle must be equipped with an anti-locking system/ anti-lock device and may not exceed an overall mass of 3.5 tons.
 - b) The caravan must be equipped with hydraulic vibration dampers (shock absorbers); naturally, your new Fendt caravan is equipped with these.
 - c) The caravan's tires may be no more than six years old. They must be marked at least with an L (= 120 km/h) for the appropriate speed category.
 - d) The caravan must be equipped with a stabilising unit in accordance with ISO 11555-1

The maximum permissible weight of the caravan may not exceed the mass of the base vehicle when ready to drive.

5. Free interchangeability of base vehicle and caravan:

Different caravans may be combined with different base vehicles.

You are responsible for ensuring that the preceding regulations are met if you plan to drive at 100 km/h. Should this not be the case, the maximum speed in Germany is 80 km/h!

6. The correct drawbar load gives you more safety:

Please refer to page 8 for the recommended drawbar load.

3.10 Definition of mass**Definition of masses (weights) for caravans**

EU Directive 1230/2012 applies at a European level for calculating the masses (weights) and resultant additional loads for caravans. The terms and basic calculation elements used in this description are explained in the following:

1. Gross vehicle weight rating (g.v.w.r.)

The indication of the gross vehicle weight rating is taken directly from Fendt-Caravan. This mass takes into account the specific operating conditions that are based on the model of the caravan and its performance, including such factors as material strength, load-carrying capacity of the axles and tyres, etc. For safety reasons, this mass must never be exceeded!

2. Mass in running order

The mass in running order corresponds to the weight of the empty vehicle including all standard equipment installed at the factory plus the basic equipment such as gas and water (driving fill level).

3. Basic equipment

The basic equipment consists of all objects and fluids which are necessary for the safe and proper use of the vehicle. These include the masses for gas and water (driving fill level). **(see Item 13.4 for a detailed specification).**

4. Additional equipment / optional extras

Mass of the equipment that was assembled by the manufacturer in or on the caravan in addition to the standard equipment. These optional extras will be shown in the actual mass of the vehicle if they are not part of the standard scope of equipment and Fendt-Caravan has been responsible for assembling or enclosing them.

5. Actual mass

The total of the mass in running order and the special or additional equipment installed or included at the factory.

6. Minimum loading capacity

The loading capacity must be equal at least to the formula:

$10 \times (n + L)$, whereby:

n = highest number of sleeping spaces

L = total length of the superstructure



The remaining additional load must always be greater than or equal to the minimum loading capacity ; this must be taken into account when determining the configuration of the vehicle.

Removing some or all of the equipment and liquids included in the tables in **Chapter 13.4 (Basic equipment)** will increase the payload/additional load by the corresponding amount.

If you are not sure whether you have overloaded the vehicle, weigh your vehicle on a public vehicle scale.



Overloading can lead to malfunction or even tire blow-out!

This presents the danger of the vehicle spinning out of control, which endangers you as well as other drivers and pedestrians.

4.1 Tires

Only use those tires designated in the registration documents. Other tire sizes may only be used with the permission of the manufacturer (ABE).

- Check tires regularly to ensure that the tread is worn down evenly; check tread depth; check for external damages.
- Always use the same make and model of tires (summer or winter tires).
- Drive carefully on new tires for a stretch of approx. 100 km to enable them to develop a full road grip.



Due to the type of construction, the tires on caravans with a tandem axle may wear out more quickly.

4.2 Tire pressure

Only one tire size has been entered in the motor vehicle registration certificate (parts I and II). This does not have to be consistent with the size of the tires on the vehicle. Should you have any queries, please contact your contractual partner.

Rules for checking tire pressure

- Check and adjust tire pressure every four weeks (but at least every three months) and before every drive.
- If driving on low tire pressure is unavoidable (i.e., from the campsite to the nearest service station) you should drive at a maximum speed of 20 km/h.
- Raise the pressure of the base vehicle's rear tires slightly. When doing so, please also refer to the base vehicle manufacturer's tire pressure recommendations.
- Tires must be checked when they are cold.
- If tires are checked or the tire pressure corrected when tires are warm, the pressure must be up to 0.3 bar higher than if the tires are cold.

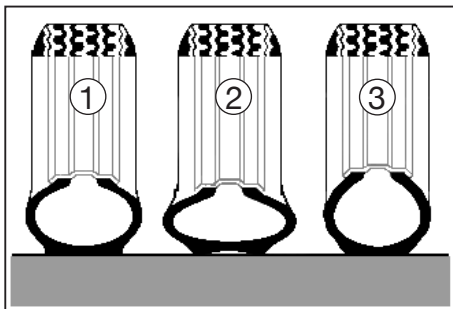

Varying tire pressures

Rules for tire pressure

- correct tire pressure ①
- tire pressure too low ②
- tire pressure too high ③



If the tire pressure is too low, the tire can overheat. This can result in serious damage.



Please refer to the table on tires/tire pressure in the chapter on „Technical Data“ or the label in the gas-bottle container for the correct tire pressure.

4.3 Profile depth and age of tires

New tires are needed (at the latest) when the profile depth measures 1.6 mm.



Tires age even when used rarely or not at all.

Tire manufacturers' recommendation

- Change tires after six years, regardless of profile depth.
- Avoid striking curbs, potholes or other obstacles.

Age of tires

Tires should not be more than 6 years old, because on the one hand your permission to drive the caravan at 100 km/h will elapse after this period and, on the other, the material wears out due to age and if the tires stand too long in one spot. The 4-digit DOT number on the side of the tire (if necessary, check the inside) shows the date of manufacture. The first 2 digits refer to the week, the last 2 to the year it was manufactured.



Example:

DOT 0223 refers to week 02 in manufacturing year 2023.

4.4 Rims

Only use rims that are covered by the vehicle licence. Should you wish to use other rims, please note the following:

Rules for the use of other rims:

- Size,
- mechanisms,
- compression depth and
- the load/bearing capacity must be sufficient for the permissible total mass.
- The chuck cone of the fastening screw must correspond to the rim mechanisms.



Modifications can only be made with the manufacturer's permission.

Rules for wheel screws

- wheel bolts must first be checked after a distance of 50 km and then checked during regular maintenance.

Adjusting torque

- for steel rims: 105 Nm
- for aluminium rims: 120 Nm

**WARNING:**

When changing rims (steel -> aluminium / aluminium -> steel) ensure that you are using the correct wheel screws.

Licensed sizes for metal wheel rims for subsequent fitting of spare wheels:

(Information only valid for standard wheel/tire combinations and/or original Fendt accessories)

Single-axle vehicles up to a max. permissible maximum weight of 1,750 kg:

- metal wheel rim 5.5Jx15 or 6Jx15
- offset 30, bolt circle 5x112
- wheel bolt: spherical wheel bolt M12x1.5x25 - 8.8 - SW19



Where the maximum permissible weight is 1,800 kg or more, only aluminium wheel rims 6Jx15, ET 30, LK 5x112 with a sufficient payload are permitted.

Wheel bolt: cone washer M12x1,5x28 - 10.9 - SW17

Tandem vehicles with 14" tires

- metal wheel rim 5.5Jx14 or 6Jx14
- offset 30, bolt circle 5x112
- wheel bolt: spherical wheel bolt M12x1.5x25 - 8.8 - SW19

Tandem vehicles with 15" tires

- metal wheel rim 5.5Jx15 or 6Jx15
- offset 30, bolt circle 5x112
- wheel bolt: spherical wheel bolt M12x1.5x25 - 8.8 - SW19

All other types of vehicles: only upon request.

Your Fendt caravan dealer will be pleased to provide you with competent advice if you have more detailed questions.

4.5 Changing the tire



Wheel chocks in the bottle compartment

Preparing to change the tire

- If possible, only change the tire when the base vehicle is coupled to the caravan.
- Park the trailer carriage on as firm and even a surface as possible.
- If you have tire trouble on a public road, turn on your hazard warning signal lights and set up the warning triangle.
- Base vehicle: Pull the handbrake, set the wheels straight, put the vehicle in gear or, if you are driving an automatic, set the gear to P.
- Caravan: Pull the handbrake, leave the support wheel in its driving position, deactivate the stabilization system (**note: do not open completely**).
- Remove the wheel chocks ① from the bottle compartment.

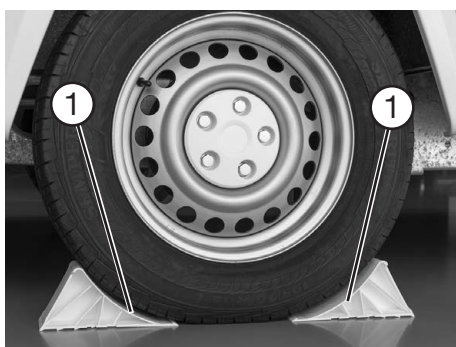

Place the wheel chocks in front of and behind the wheel

- To secure the vehicle, place the wheel chock ① in front of and behind the wheel that is still intact.
- Before jacking up the vehicle, turn the wheel screws once to loosen them, but do not unscrew them any further.



- The spare tyre with mount (**model/series-specific, optional extra**) ② can be stored at the front of the caravan by the gas bottle container. (The mount will only be included in the scope of delivery if the spare tyre is fitted at the factory.)



If the caravan has alloy rims, note that the correct wheel screws are used when installing the spare tire affixed to a steel rim.

Warnings for changing the tire



Mount a suitable car jack on the appropriate parts of the frame. For example to the reinforced material near the screwed connection on the chassis frame / axle carrier behind the axle.

Damage or even an accident resulting from the vehicle's toppling over can occur if the jack is applied to other parts of the vehicle.

The jack is only to be used for changing tires. It may not be used for working under the vehicle!

The rotating stanchions may not be used as a jack!



The jack is not part of the standard equipment in this series, and is therefore not included.



After changing the tire, the wheel screws must be examined (after a 50 km drive) to ensure that they are tight enough (tighten if necessary).

Changing the wheel

- Mount a suitable car jack on the appropriate parts of the frame. For example to the reinforced material near the screwed connection on the chassis frame / axle carrier behind the axle.
- If the vehicle is parked on soft ground, lay a stable reinforcement under jack (i.e., a board).
- Lift the vehicle until the wheel is 2 or 3 cm off the ground.
- Reposition the ratchet jack handle if it should slant when you jack up the vehicle.
- Remove the wheel fastening screws and the wheel.
- Attach the spare tire to the hub and adjust it.
- Reattach the wheel screws and tighten them lightly over the transversal.
- Lower the jack and remove it.
- Tighten the wheel fastening screws evenly with the wheel wrench. The nominal value of the attachment torque is 105 nm for steel rims and 120 nm for aluminium rims.
- Release the handbrake and reactivate the stabilization system



You should have a functional spare tire available at all times. Therefore, have the spare tire replaced without delay.

5.1 Ventilation and De-aerating

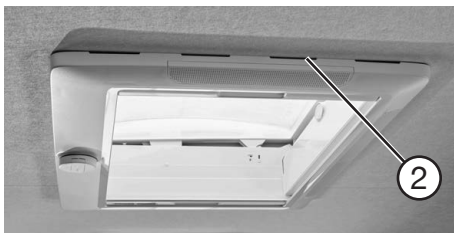

The following applies for forced ventilation

Correct ventilation and de-aerating of the caravan is a prerequisite for feeling comfortable inside the caravan. Vents for forced ventilation have been integrated in the floor ① of your caravan; for forced de-aerating, they have been integrated in the roof bonnets ②. You must not interfere with their mode of operation.



We recommend that you open the roof bonnets whenever you live in the caravan.

Under no circumstances may the safety ventilation be shut, not even slightly.

The ventilation openings must always be kept clean and free of dust.



Cooking, wet clothing, etc., produces vapor. Every person loses up to 35 g of water per hour. Therefore, depending on the relative humidity, please ventilate and de-aerate through the windows and roof bonnets (see also "**Winter operation**").

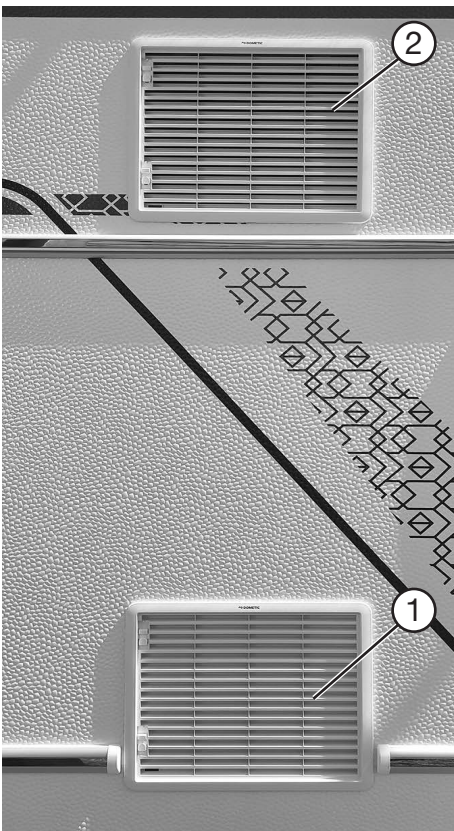

Ventilation grille on the refrigerator (model-specific)

The ventilation bars provide the refrigerator with fresh air from outside to ensure sufficient cooling performance. The ventilation grille ① is generally located at the bottom of the outer wall of the vehicle. The de-aeration bar ② is located above the ventilation bar.



We recommend that you remove the ventilation bars when outside temperatures are very high. This creates a high air circulation on the refrigerator and increases cooling capacity. The ventilation grids must be firmly mounted when it is raining or while driving.

Special cover plates should be used during winter operation. You can buy these cover plates from your dealer.



There is a danger of suffocation if ventilation openings are blocked! Therefore, do not block ventilation openings.

Note the information on the cover plates. The cover plates may only be used in winter if the refrigerator is operated electrically verwendet werden.

Pictures may vary somewhat from the equipment in your caravan.

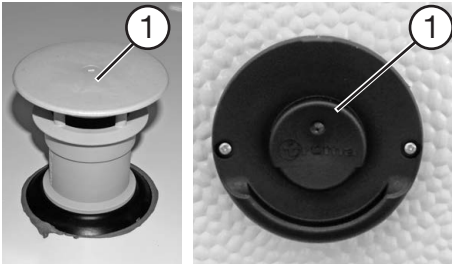

Flue (model-specific)

Heating element

The heating system is supplied with fresh air via ventilation openings beneath the floor of the vehicle. The air from the heating element is carried outside by a flue.

For the Truma heating model Combi 4 or 6, fresh air is taken in and exhaust air is expelled via the wall flue.

The flue ① is located on the roof of the caravan or on the side wall.



There is danger of suffocation if flue openings are blocked!
Therefore, do not block flue openings.

Ensure unobstructed outflow from the flue during winter operation.

5.2 External entry



Pictures may deviate from the actual model, depending on the model/layout plan.



The external entry door has been designed for use in leisure vehicles. There are two different versions:

- Caravan external entry door with hinges on the right
- Caravan external entry door with hinges on the left

The entry door is your escape route in an emergency. Therefore, never block the door from the outside!

Only drive when the entry door is shut! Always check that the external entry door has been correctly locked before driving.

The inside of the entry door has been fitted out with storage shelves. These storage shelves must never be misused as a means of closing the door.

In some models, there may be a danger of collision when opening the entry door if the window in the side wall is open. If the wind is gusting. Always close the external entry door carefully and in a controlled manner! Make sure that no one, particularly children, is in the door's opening area! There is a considerable risk of crushing-type injuries!

Only use the insect screen door (model-dependent / special accessory) when the external entry door is open!



The entry door has been constructed in such a manner that there is a certain initial tension around the lock to ensure that the seal around the door leaf rests correctly at the top and bottom against the door frame.

Occasionally, this may cause a slight tension in the locking mechanism of the door and when opening the door from outside by pulling on the door handle. Pressing lightly against the door leaf near the lock releases this constructively designed initial tension, allowing the door handle to be used easily.



Please do not pull violently on the outside handle or twist it, because this will have a negative effect on the gliding quality of the latch and the ability to move the lock freely.

Unlocking the external entry door from the outside



The instructions for the locking mechanism and illustrations are for doors with hinges on the right. As a matter of principle, the locking mechanism for doors with hinges on the left functions the opposite way round.

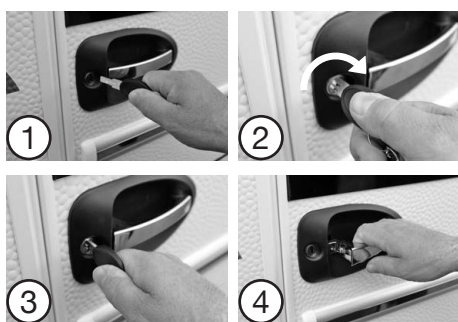

- Insert the key into the locking cylinder ①.
- Turn the key clockwise to the right until the lock is unlatched ②.
- Turn the key back to the central position and pull it out of the lock ③.
- Open the entry door by pulling the handle towards you ④.

Locking the external entry door from the outside



Danger of crushing-type injuries!

Always close the external entry door carefully and in a controlled manner! There is a considerable risk of crushing-type injuries!

Avoid pressing the internal lock knob **at the same time** as you pull the door handle from the outside – this can cause the unlocking mechanism to block and damage the lock!

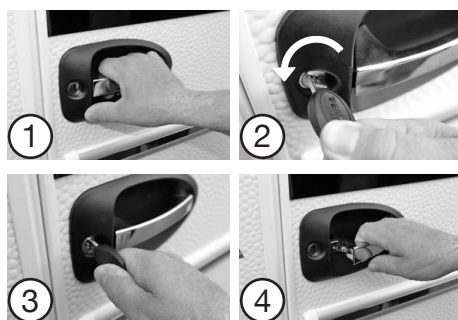

- Shut the entry door ①.
- Insert the key into the locking cylinder and turn it anti-clockwise until the latch clicks audibly ②.
- Turn the key back to the central position and pull it out of the lock ③.
- Pull the door handle to check that the door has been locked correctly ④.

Opening the external entry door from the inside



- Pull the long release lever to unlock the entry door ①.
- Use the internal handle to push the door open to the outside ②.

Closing the external entry door from the inside



Danger of crushing-type injuries!

Always close the external entry door carefully and in a controlled manner! There is a considerable risk of crushing-type injuries!

Avoid pressing the internal lock knob **at the same time** as you pull the door handle from the outside – this can cause the unlocking mechanism to block and damage the lock!



- Pull the internal handle to shut the door ①.
- Press the small locking knob to lock the door ②.

Cleaning and care of the interior panelling of the door

Clean the ASA soft-touch surface only with water or a damp cloth. Do not use cleaning additives! Should there be coarse dirt or spots, a small amount of a mild, degreasing household cleaner / dish washing liquid may be added to the water. In case of doubt, first test the suitability of the cleaning additive in an unnoticeable spot.

Window shades



Always hold the pleated shade's top rail in the middle and move the shade up or down until you have achieved the desired degree of shade. Avoid slanting or tilting the rail when pulling it.

The pleated shade will stop moving when you let go of the rail.



To avoid damaging the window shades, always hold the rail in the middle.

To avoid damage to the window pane or shade caused by heat accumulation, never fully shut the shade if the sun is shining directly onto it.

To avoid damaged caused by material fatigue, never fully shut the shade for longer periods. Only use as required.

Insect screen door (model-specific / special accessory)

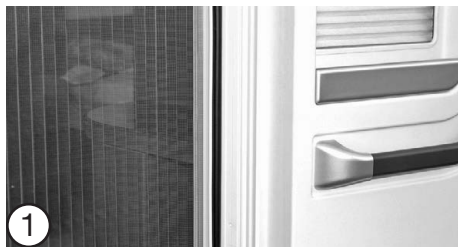

Incorrect handling may result in damage!

To avoid damage, only use the insect screen door when the external entry door is open ①!

Depending on the position of the insect screen door ③, it and/or the external entry door may be damaged if the entry door is shut ② when the screen door has not been fully closed!

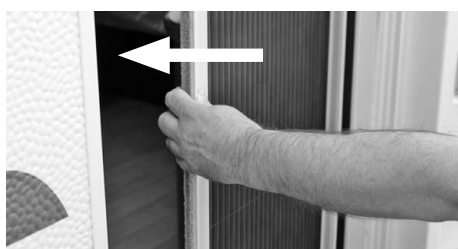

Closing the insect screen door

Always hold the rail in the middle to operate the insect screen door and pull it across the entire width of the door opening.

The insect screen door will remain in position and does not need to be separately locked.

Avoid slanting or tilting the rail when pulling it.

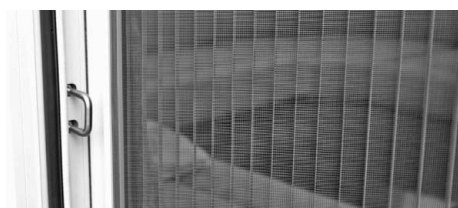

Opening the insect screen door

Always hold the rail in the middle to operate the insect screen door and pull it back across the entire width of the door opening until it can no longer be moved.

The insect screen door will remain in position and does not need to be separately locked.

Avoid slanting or tilting the rail when pulling it.



To avoid damage due to material fatigue, the insect screen door should not be left shut over a longer period of time. Only use as required.



Cleaning and care instructions for the insect screen door and pleated shades

From time to time the pleated elements of the insect screen door and window shades should be cleaned to remove dust. Use a (portable) vacuum cleaner on a low setting to do so.

The guidelines for the insect screen door and the pleated blinds on the door window should be treated regularly with silicone spray to improve their ease of operation and reduce wear and tear.

The guide rail of the insect screen door must be hoovered or cleaned regularly. Dirt or foreign matter (sand, pebbles, etc.) which collect in the guide rail lead to increased wear and tear and may even break the guideline.

Never use liquids (including water) or aggressive cleaning products! This could result in permanent damage to the pleated elements!

Cleaning and care instructions for the acrylic glass windows



Please refer to the information given in **Chapter 11.3 Upkeep** of this operation manual (**Page 100 – Acrylic glass window panes**).

General cleaning and care instructions



Maintain the doors' rubber seals by regularly applying talcum powder!

5.3 Service flap

(model-specific / special accessory)

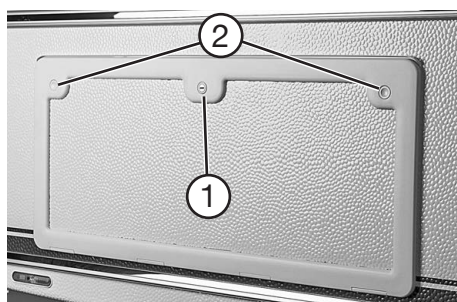

To open

- Unlock the flap ① with a key.
- Press locking knob ② while pushing lighting on the flap.
- Open the flap by pushing down.

To close

- Close the flap by pushing it up.
- Press the top left and right-hand corners of the flap to ensure that all of the existing locks actually snap into place.
- Use the key to lock the flap ①.



All of the fastenings on the service flap must lock into place when closing to ensure that the flap will always be closed tight. If the flap is not closed correctly, it could become permanently deformed, especially when the caravan stands unused for a longer period of time.



Spray the sealing gaskets of the service flaps regularly with silicon to ensure that they will always move easily and operate reliably.

Storage locker flap (model-specific)



To open

- Unlatch both locks with the key.
- At the same time, pull both locking handles outwards around the flap to open it.

To close

- Close the flap.
- Press on the flap by the locks so that the locks actually click into place.
- Latch both locks with the key.



The storage locker flap is only guaranteed to be permanently tight if all of the locks click into place when the flap is closed. If the flap is not closed correctly, it could become permanently deformed, especially when the caravan stands unused for a longer period of time.



Spray the seals of the storage locker flap regularly with silicone to ensure that the service flap always moves freely and operates reliably.

5.4 Toilet flap

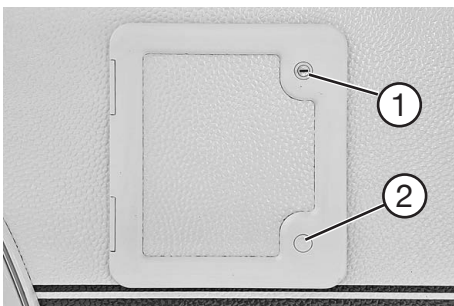

The illustration may vary from the actual flap, depending on the model and version.

To open

- Unlatch the lock ① with the key.
- Press the knob ② and swing the flap to the side.

To close

- Push the toilet flap to the side until it snaps in.
- Latch the lock ① with the key.

5.5 Gas-bottle container flap

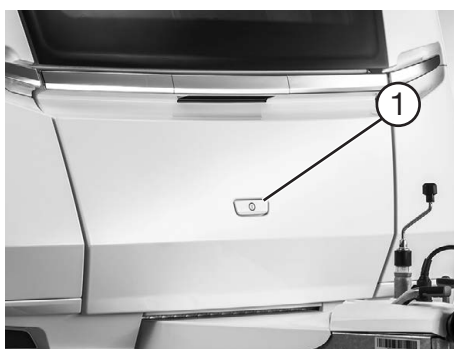

To open

- Unlatch the lock ① with the key.
- To unlock, turn the knob that pops out in a counter-clockwise direction and open the gas-bottle container lid.



Do not use the push-and-pull lock to open or close the gas container flap. There is a danger that the locking system will be damaged.

To close

- Shut the lid of the gas-bottle container.
- Press down lightly on the handle of the lid to ensure it fits snugly on the rubber gasket.
- Latch the lock ① with the key.
- Press the knob until it snaps in and secure it.

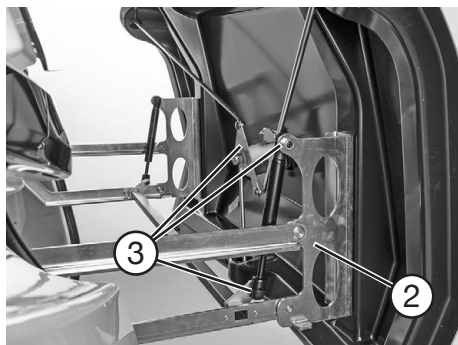

Note that, due to the scissor-shaped mounting ②, there is a danger of crushing your fingers when opening and closing the lid of the gas-bottle container.

Please note that if the front window is open, the gas-bottle container flap should not be opened or only opened with care. If the window is open at a certain angle, the gas-bottle container lid may collide with the window as it swings up.

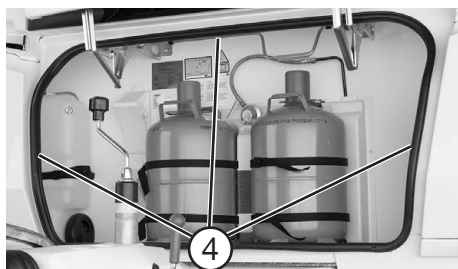

Grease and oil the lock ① / rotary disc / lock rods ③ regularly or as required. Maintain the seals ④ of the service flap by spraying them regularly with silicone.

The toggle lock will lock when in the appropriate position even if the key has been removed.

5.6 Roof and roof rail
(model-specific / special accessory)



Should you have requested that the manufacturer install special accessories in your caravan, or should your dealer have subsequently fitted your caravan with a roof rail, please note the following:

- It is not possible to walk on the roof of the caravan. No liability is assumed for any damages resulting from such actions.
- There is an increase in the danger of slipping or an accident if the roof is damp or wet.

The roof rail is merely an optical feature; it is not suitable for carrying loads.

5.7 Guide rail for outer tent



To insert the tent keder at the front or rear end, the guide rail for the outer tent has been milled out at the edge of the ornamental strip.

The illustration may vary from the actual flap, depending on the model and version.

5.8 Bicycle carrier for installation on the drawbar (special accessory)



The driving performance of the caravan changes considerably when there are bicycles on the carrier. Accordingly, the speed must be adjusted to these circumstances.

- Ensure that the maximum permissible drawbar load is not exceeded when there are bicycles on the carrier. See also Chapter 2.3.
- The critical speed sinks drastically even if the carrier has been optimally loaded.
- The driver of the vehicle is responsible for the state of the carrier and for ensuring that both the carrier itself and the bicycles have been fastened securely.
- The carrier must be secured by means of the mounting brackets and straps at hand even if there are no bicycles on it.
- Check the assembly of the carrier and the load after having driven a short distance (approx. 50 km) and again later on at reasonable intervals.
- Ensure that the load does not partially or fully cover existing illumination devices.
- The carrier has been designed to carry a maximum load of 60 kg.



Please refer also to the separately enclosed Safety Instructions provided by the product manufacturer.

When driving through tight curves or shunting, please note that the maximum steering angle car -> caravan may be greatly reduced by the bicycle carrier and its load.



To avoid a collision, we recommend that you have someone acting as a flagman when manoeuvring in reverse or in tight curves.

5.9 Subsequent installation of an awning

When selecting an awning, please note the limited amount of available space between the outer tent lamp and the surrounding aluminium moulding. Otherwise, it is only possible to install an awning on the roof.

If you prefer to install the awning on the roof of the caravan, please note that, if you have a roof rail, this is not possible or only possible in a very limited way.

If you have any queries, please speak to your Fendt-Caravan dealer.

Furthermore, we recommend that you have the awning installed by a specialised company, if only for liability reasons.

The maximum permissible total width and total height may not be exceeded by installing an awning.



Installing an awning may have a negative influence on the trailer/driving performance of the caravan.

6.1 Doors, flaps, drawers and kitchen worktop



Drawers and furniture doors with a push lock (press-lock knob)

To open:

- Press the push-lock until the knob jumps up.
- Pull on the knob or handle until the drawer slides out or the flap or door opens.

To close:

- Push on the knob to close the drawer or the door.
- Press the push lock (press-lock knob) until the knob snaps in and the drawer or door is securely closed.



Close all doors and flaps properly before driving. This prevents them from opening accidentally and objects falling out while driving.



Kitchen drawer with self-closing runner (model-specific)



Please observe the maximum load of 10 kg per drawer as well as for the pantry pull-out (**model-specific**). No liability is assumed for any damages resulting from overloading.



Toilet/shower doors



Do not hang wet bathrobes or towels on the hooks at the top of the toilet/shower door. Moisture can work its way through the minute holes in the decorative foil into the wooden structure, which may cause parts of the foil to come off.



Desk (Apero Connect)



While driving, the desk must be closed and secured using the strap ① provided for this purpose.

6.2 Converting the seating arrangement into a bed



In most caravans, the seating arrangements can be converted to beds if required.

Here is some useful information for doing this:

- Remove the seat and back cushions.
- Release the bolting device for the pillared table frame or table leg.
- Lower the table frame or place the hinged table on the prepared strips of the seating chests.
- If necessary, widen the seating benches.
- Replace the seat and back cushions as shown in the pictures.



Position the lowered table in the middle of the seating arrangement. Do not leave it in the transport or driving position.



When converting seating arrangements into beds, do not place the cushions directly on the tabletop as this may cause scratches or mildew due to condensation. We recommend that you use an absorbent cloth (e.g. terry cloth or cotton).

Ensure that the tabletop, seat chests and/or covers as well as cushions are well secured so that nothing can fall.



Some caravan models do not require seat and/or back cushions when converting seating arrangements into beds.

Only for „Valencia" fabric upholstery:

Instead of the back cushions, the levelling cushions included in delivery are required to convert the arrangement into a bed.

While driving, the table must be brought to its lowered position and secured with the straps attached to the bench.

Operating the different types of table frames

Lifting frame with control lever (model-specific)

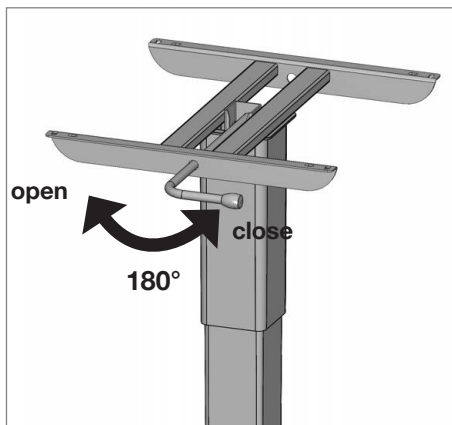

To operate

- Turn the lever by 180° to release or set the brake.
- The table can be locked into place in the upper and lower position.



When pulled out, the table frame is fully adjustable by approx. 100 mm.



The table leg could be deformed if heavy loads are placed only on one side, e.g. because it has not been secured properly while driving and therefore falls or slips in the trailer.



Converting a round seating arrangement into a bed (APER0/BIANCO/TENDENZA)



In some caravan models (e.g. wide vehicles) additional cushions (*) have been included separately. These are required for adjustment when converting the arrangement into a bed.



Converting a round seating arrangement into a bed (DIAMANT)



The extra cushions (*) are only required when converting the seats into a bed; otherwise, they are stored.

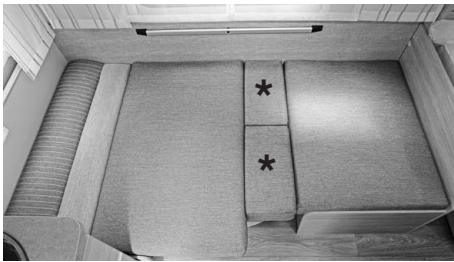

Converting the seating arrangement into a bed (390 FHS)



The extra cushions (*) are only required when converting the seats into a bed; otherwise, they are stored.



Converting the seating arrangement (dinette) into a bed (515 SGE, 495 SFE)

- Fold in the articulated support leg and place the table top on the designated support bars between the seating benches.
- Fold out the support bracket ①.
- Place the cushions as shown in the drawing on the left.

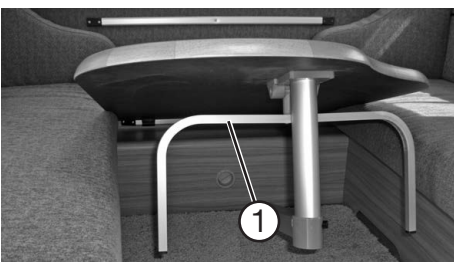

(465 TG / 465 SFH / 495 SG / 550 SD)

- Lower the table frame.
- Place the cushions as shown in the drawing on the left.



Extending the bench seat as a footrest (Optional extra – model 465 SFH only)

- Release the pushlock button on the side of the bench.
- Flip the side of the bench up and fold out the supporting board until it locks into place.
- Arrange the additional cushions on it.
- To fold the supporting board and the side of the bench away, press the lever of the locking mechanism and return the extension to its original position.



Extending the bench affects the passage width of the entrance door - and thus the emergency escape route.



Converting the centre round seating arrangement (560 SKM)



The extra cushions (*) are only required when converting the seats into a bed; otherwise, they are stored.



Converting the centre seating arrangement into a (495 SKM/515 SKM/550 KMG)

- Fold in the articulated support leg and place the tabletop on the designated support bars between the benches.
- Place the cushions as shown in the photo on the left.



The extra cushions (*) are only required when converting the seats into a bed; otherwise, they are stored.



Converting the centre seating arrangement into a (515 SKF)

- Fold in the articulated support leg and place the tabletop on the designated support bars between the benches.
- Fold out the support legs of the separately enclosed levelling piece for the bench ① and insert it in front of the tabletop between the benches.
- Place the cushions as shown in the photo on the left.

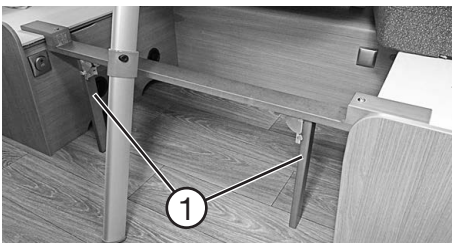

The extra cushions (*) are only required when converting the seats into a bed; otherwise, they are stored.



(550 SKM / 515 SGD)

- Fold in the articulated support leg and place the tabletop on the designated support bars between the benches.
- Place the cushions as shown in the photo on the left.



Converting the L-shaped seating arrangement into a bed (optional extra for BIANCO 465 SGE)

- Position the storage box and place the cushion and levelling cushion as shown in the picture to the left.



The maximum load for the occasional ottoman is 100 kg.



Folding stool (model-specific/country-specific/optional extra)



The maximum load for the folding stool is 130 kg.

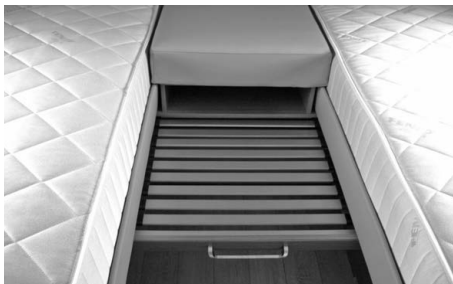

Bed filler with extendable slatted frame (special accessory/for single bed model only)



The two levelling cushions can be joined together with a zipper.



Fold-away bed (BIANCO 515 SKF)



To fold the bed away, only push the slatted frame from the interior of the vehicle towards the wall and when the mattresses have been stacked one on top of the other.

To open: Take hold of the loop on the side of the slatted frame and pull on it until the frame clicks into the desired position.

To close: Use the loop to pull briefly on the slatted frame until the lock opens and then pull the slatted frame down into place.

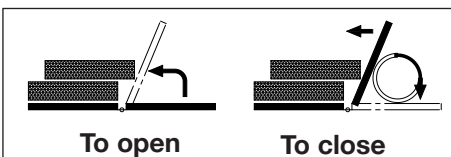

6. Interior structure



Pictures may vary somewhat from the equipment in your caravan.

Moveable bed

(TENDENZA 560 SFDW, 650 SFD)

- To adjust the slatted frame, raise the head end of the mattress and position the slatted frame as desired.
- To return it to the reclining position, the slatted frame must first be moved as high as it will go and then unlocked.

6.3 Bunk beds

(560 SKM)



Model-specific



The maximum load for the upper bunk bed is 75 kg.



Be careful when using the upper bed for small children, as there is a danger that they may fall out. Never leave small children unattended in the caravan.



Small children under the age of 6 may not use the upper bunk bed.
Please note our safety symbol!

6.3.1 Bunk beds in models with a rear flap / rear external storage locker (495 SKM, 515 SKM, 515 SKF, 550 SKM, 550 KMG)



The maximum load for the upper bunk bed is 75 kg.



Be careful when using the upper bed for small children, as there is a danger that they may fall out. Never leave small children unattended in the caravan.



Small children under the age of 6 may not use the upper bunk bed.
Please note our safety symbol!



The lower bunk bed can be folded up. Ensure that it is securely fastened by means of the Tenax fasteners on the right- and left-hand side.

Together with the rails/lashing rings (**model-specific**) and the large external flap, this also allows you to use this space as an external storage locker.

Shifting the lashing rings (model-specific)

- Give the lashing ring half a turn counter-clockwise and push it to the desired position in the fastening rail.
- Then give the lashing ring half a turn clockwise. The lashing ring is now firmly locked in the fastening rail.



Always check that the lashing rings are firmly locked before you start your drive.

The owner/driver of the vehicle is always responsible for ensuring that loads transported in the external storage locker have been correctly secured. As far as possible, always use tension belt systems licensed for this purpose.

Never use rubber expanders. Remember that exceptionally strong driving dynamics can occur in dangerous situations or when you are forced to slam on the brakes.

Please note the information given in **Chapter 2.3** of this operating manual regarding correct loading and the drawbar load.

Please note: the heavier the rear load, the worse the driving performance and brake response.



When stowing bicycles, it may be necessary to disassemble the front wheels. We recommend the use of an additional, special fixing bracket on the floor (**optional extra**) to secure the bicycle fork and protect the PVC floor.



In the above-mentioned models, the upper bunk bed can also be folded away.



Take care when folding the upper bunk out or in as there is a risk of pinching or crushing your fingers!

When folded out, the upper bunk bed must be secured by means of the belt provided for this purpose.

The upper bunk bed must be folded in when driving.

Before driving, fold the upper bunk bed in and use the Tenax fasteners located on the right-hand side (in the direction of traffic) to secure it in the predefined position.

In models 515 SKF and 720 SKDW, the ladder must be securely fastened in the predefined position while driving.

6. Interior structure

6.4 Windows



Please refer to the separate, enclosed Users' Manual provided by the device/product manufacturer,  **Dometic**, for useful information on operating and caring for the windows.

Due to condensation, a light mist may form between the acrylic glass double pane if there are excessive differences in temperature. However, the pane has been constructed in such a way that, as the temperature outside increases or the individual climate zones are adjusted, this condensation will evaporate by itself. This is a physically explainable occurrence; it does not mean that the pane itself is defect.



Risk of damage from heat build-up between blind and window pane!

In case of strong sunlight, the shade may be pulled down no more than two-thirds of the way.



Window shades (DB3 shade/adjustable blind) (model-specific)

Please refer to the separate, enclosed Users' Manual provided by the device/product manufacturer,  **Dometic** for useful information on operating and caring for the window shades.



Risk of damage from heat build-up between blind and window pane!

In case of strong sunlight, the shade may be pulled down no more than two-thirds of the way.

Risk of damage

- Never let the shade spring back into its original position.
- Use the handle to pull the shade and fly screen to the desired open position.
- To prevent material fatigue, do not leave the blinds closed for a longer period of time.

6.5 Roof bonnets



Please refer to the separate, enclosed Users' Manual provided by the device/product manufacturer  **Dometic** for useful information on operating and caring for the roof bonnets/ventilation.



Risk of damage from heat build-up between blind and window pane!

In case of strong sunlight, the shade may be pulled down no more than two-thirds of the way.

7.1 Safety tips

The installation of electrical devices in the Fendt caravan have been carried out in accordance with the valid regulations and norms.

Please note:

- Do not remove safety tips and warnings on the electrical equipment.
- The installation spaces for electrical equipment such as distribution fuse boards, electric power supply, etc., may not be used as additional storage spaces.
- Only authorised specialists may work on the electric system.
- **If the vehicle is equipped with a battery: (optional extra, country-specific, model-specific)**
Only those accumulator batteries may be used which have charging characteristics which match the charger or the charge controller. (LiFe, gel or AGM batteries)
- Turn off all equipment that uses 12V before connecting or disconnecting the battery.

7.2 Electrical supply

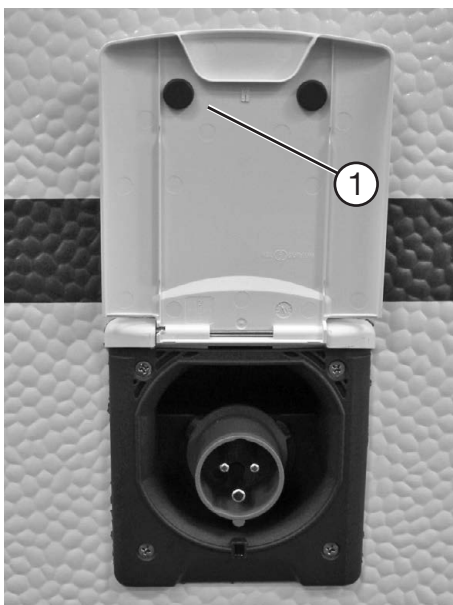

Electricity for the caravan can be obtained from the following connections:

- 230V mains connection 50 Hz.
- via the base vehicle if it is connected using the 13-pole plug (limited functions)
- via a built-in auxiliary battery (special request). All of the standard equipment that uses 12V, such as lighting, water supply, etc., is available. This also applies for the compressor refrigerator, but not for the absorber refrigerator. For further information, please refer to Chapter 9.4, p. 92.

The 230V system is protected by a two-pole 13 A automatic circuit breaker ④, which is located in the wardrobe. (Exceptions to this include special installations such as ultraheat, hot-water heating, etc. In this case, an additional two-pole 13 or 16 A overload circuit breaker ③ is installed.)



The bolted connections of the circuit breakers as well as the secure fit of the connection cable must be checked once a year by a specialist and, if necessary, tightened.

The residual current operated device must be checked regularly by pressing the test button.

Supply via mains connection

The caravan receives its electric power supply via the 230V CEE feeder plug on the side wall of the vehicle.

To connect:

- Turn off the automatic circuit breaker ④ by pressing the rocker switch ③ down.
- Grab the bottom of the protective cover ① of the exterior socket and flip it up.

7. Installation of electrical devices

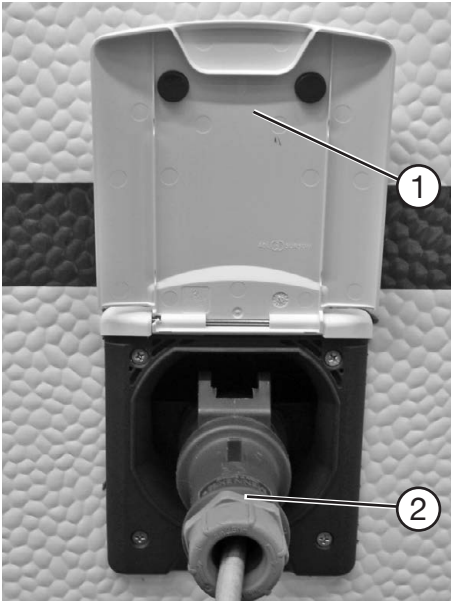

Pictures may vary somewhat from the equipment on your caravan!

- Completely unwind the connector cable and attach the CEE plug ② .
- Turn the automatic circuit breaker ④ back on.

To disconnect:

- Turn off the automatic circuit breaker ④ by pressing the rocker switch ③ down.
- Pull out the CEE plug ② .
- Fold down the cover flap ① .

Rules for the mains connection:

- Use only a 3 x 2.5 mm² cable with a maximum length of 25 m, a CEE plug and connector to connect the caravan to an external 230 V mains.



If the mains operates via a cable drum, this must be completely unwound, as otherwise induction may cause the cable to heat up and burn.

- The 230V mains connection in the caravan has been designed for a total power consumption of 2900 W. If additional devices requiring electricity are connected, such as water heaters, etc., you must ensure that this electric power value is not exceeded, taking other electrical equipment into account that is in use, e.g. refrigerator, therme, etc.



Please observe the manufacturer's  Dometic separately enclosed operating instructions for the device/article.





Overload protection (special accessory only or model-specific)



Please observe the manufacturer's  Dometic separately enclosed operating instructions for the device/article.

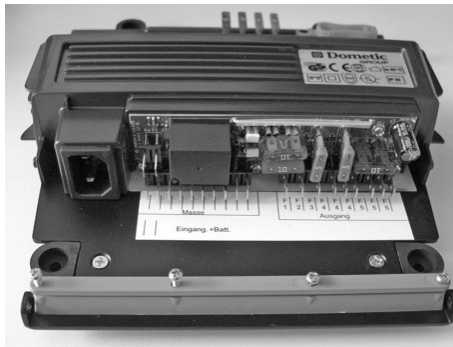

Assignment of fuses for power supply (Models APERO, BIANCO)

Fuses are assigned as follows (from left to right):

- 1st circuit 1 / 10A
- 2nd circuit 2 / 10A
- 3rd circuit 3 / 5A
- 4th circuit 4 / 5A
- 5th circuit 5 / 10A

The illustration above shows the device without its cover.



Please also note the separately enclosed circuit diagram for the 12V electrical supply.

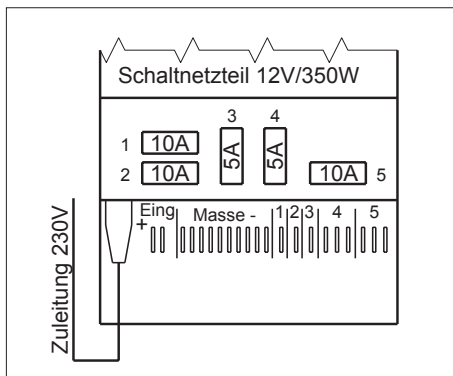

Depending on the model the assignment of fuses may vary somewhat from the equipment from your caravan.



On no account should the power supply fuses be replaced with fuses with incorrect sockets or higher ampere ratings.

Pictures may vary somewhat from the equipment on your caravan!

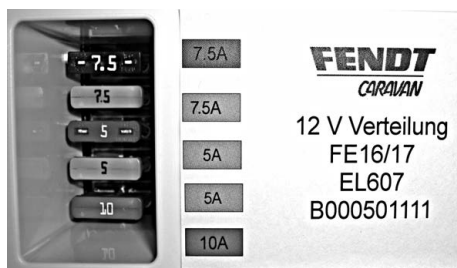

Switch box and assignment of fuses (TENDENZA, DIAMANT caravan only)

The fuses have been assigned as follows (from bottom to top):

1. Electric circuit A / 10A
3. Electric circuit C / 5A
4. Electric circuit D / 5A
5. Electric circuit E / 7,5A
6. Electric circuit F / 7,5A



Please also note the separately enclosed circuit diagram for the 12V electrical supply.

Further information on the individual electric circuits is given in the next **Chapter 7.4 Light control system**.

The 10A fuse for the second electric circuit B and for the seventh electric circuit G is located beneath the cover of the switch box.

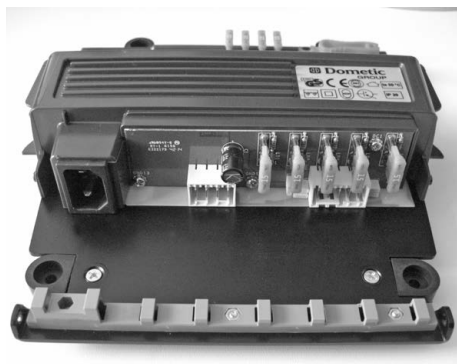

The illustration above shows the device without its cover.

Picture may vary somewhat from the equipment on your caravan!

The fuses in the switching power supply protect the feed line to the switchbox.



On no account should the fuses for the power supply or the switch box be replaced with fuses with incorrect sockets or higher ampere ratings.



Depending on the model the assignment of fuses may vary somewhat from the equipment from your caravan.

7.3 Controls, switches, sockets in the kitchen unit (for APERO, BIANCO models only)

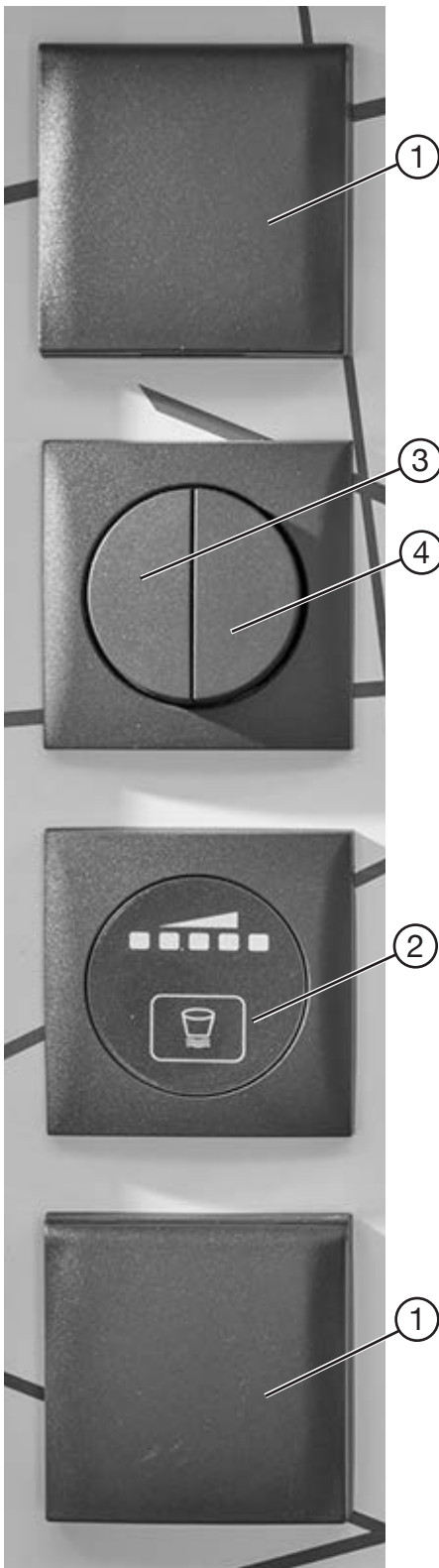

- ① Sockets 230V
- ② Fresh water tank display
- ③ Indirect lighting 12V
- ④ Workplace lighting

Picture may vary somewhat from the equipment on your caravan!

7.4 Lighting control system with switch/touch panel / Bluetooth control (TENDEZZA, DIAMANT)

The system consists of control electronics, a control panel with a keypad and, depending on the model/layout plan, several external control panels. Depending on how the trailer is equipped, it enables different lights, diverse 12V/230V electrical devices and the displays for the filling levels and consumption to be operated.

Master control panel for the lighting system and filling level display

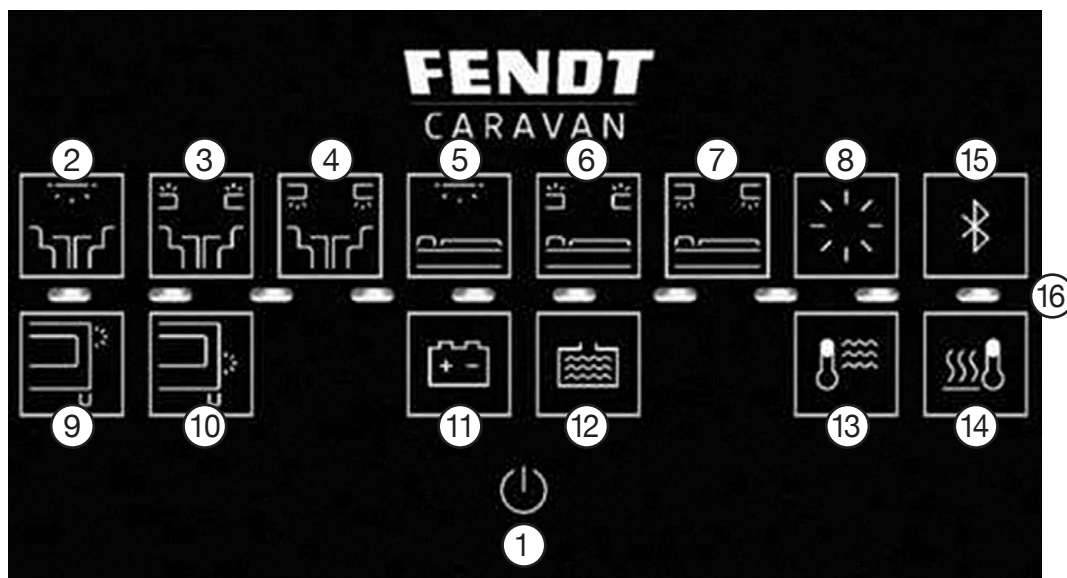

Description of the key functions / LED strip

- | | |
|--|--|
| ① Main switch with LED display | ⑧ Switch for lighting in bar/chest of drawers/
side panel seating bench |
| ② Switch/dimmer for ceiling light, living room | ⑨ Switch for outer tent light |
| ③ Switch/dimmer for LED strip on the upper
roof storage box / ceiling light, living room,
ambience | ⑩ Switch/dimmer for the light in the awning rail/
outer tent ambience |
| ④ Switch for LED strip on the lower roof storage
box / corner shelves, living room | ⑪ Battery management (model or series-specific/
optional extra) |
| ⑤ Switch/dimmer for ceiling light or LED strip,
bedroom | ⑫ Filling level display of the fresh water tank |
| ⑥ Switch/dimmer for LED strip on upper
roof storage box / ceiling light, bedroom,
ambience | ⑬ E-Boiler/therme with LED display
(model/series-specific) |
| ⑦ Switch for LED strip on lower roof
storage box – bedroom | ⑭ Electrical floor heating with LED display
(model-specific/optional extra) |
| | ⑮ Bluetooth connection |
| | ⑯ LED strip (filling level display) |



Press keys 11 and 12 (> 1 second) to disconnect the existing Bluetooth connection to the Fendt Caravan Connect app. The LED luminous band will blink briefly to confirm disconnection.

Description of the individual key functions



① **Main switch with LED display**

Briefly press on the “Main switch” key to switch off all of the lighting circuits (D, E, F). The state of operation of the lighting circuits will be saved when the main switch is switched off. Pressing the main switch again will switch the lighting circuits (D, E, F) back on. The circuits “230V floor temperature control system” and “230V boiler/therme” are not switched off automatically.

As long as the power supply has not been interrupted, the devices will then be in the same state of operation as before. Pressing the main switch for a longer period of time (> 3 seconds) switches the lighting circuits (C to F), the circuits for the floor temperature control system and the boiler/therme as well as the fuse circuits A and B off. This does not include the connection for the refrigerator and the heating system, nor the CP plus control panel. These devices always remain connected to the power supply.

Press the key  for approx. 9 seconds to switch all of the fuse circuits (A to E) on.



② **Switch/dimmer for ceiling light in living room**

Press briefly on the key to switch the spots on the ceiling in the living room on and off. Press longer on the key to regulate how brightly you want the spots to shine.



③ **Switch/dimmer for LED strip on the upper roof storage box/ceiling light, living room, ambience**

Press briefly on the key to switch the upper LED rope light for the overhead storage compartment or the living room ceiling light's ambience lighting on and off. Press longer on the key to regulate how brightly you want the spots to shine.



④ **Switching the LED strip on the lower roof storage box/corner shelves, living room**

Press this key to switch the LED strip on and off.



⑤ **Switch/dimmer for ceiling or LED strip - bedroom (depending on model/layout/country-specific)**

Press briefly on the key to switch the spots on the ceiling in the bedroom on and off. Press longer on the key to regulate how brightly you want the spots to shine.

This key is not meant for the lighting in the air-conditioning system.



- ⑥ **Switch/dimmer for upper LED strip light for overhead stowage compartment/ambience ceiling light in bedroom**
(depending on model/layout/country-specific)

Press briefly on the key to switch the upper LED rope light for the overhead stowage compartment or the bedroom ceiling light's ambience lighting on and off. Press longer on the key to regulate how brightly you want the spots to shine.



- ⑦ **LED strip lower roof storage box – bedroom**

Press this key to switch the LED strip on and off.

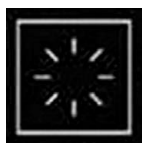

- ⑧ **Switch for lighting in bar/chest of drawers/side panel seating bench**
(depending on model/layout / country-specific)

Press this key to switch the lights for the bar, sideboard or bench plinth on and off.



- ⑨ **Switch for outer tent light**

Press this key to switch the outer tent light on and off.



- ⑩ **Switch/dimmer for the light in the awning rail/outer tent ambience**

Press this key to switch the LED luminous band on the awning rail and the lower light in the outer tent on and off. Press longer on the key to regulate how brightly you want these lights to shine.

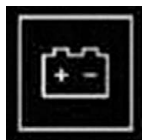

- ⑪ **Battery management**
(model-specific/optional extra)

When this key is pressed, the current status of the battery is displayed by means of a luminous LED band ⑯. When the charging status of the battery is very low, the outer left LED on the luminous band will start to blink.



The temperature of the battery must not exceed 50° C.

7. Installation of electrical devices



12 Filling level display of the fresh water tank

When this key is pressed, the filling level of the fresh water tank is displayed by means of a luminous LED band (16). When the filling level of the fresh water tank is very low, the outer left LED on the luminous band will start to blink.



Align the trailer horizontally to obtain a meaningful result from the filling level indicator.



13 E-Boiler/therme with LED display (model/series-specific)

Press this key to switch the hot water device on and off. An illuminated LED signals that the device has been switched on. If the main switch is pressed for a longer period of time (> 3 seconds), the hot water device will also be switched off.



In vehicles which have been equipped with a Combi or Alde trailer heating system (**model-specific / optional extra**), no functions have been assigned to the switch even though the control LED lights up.



14 Electrical floor heating with LED display (model-specific/optional extra)

Press the key to switch the floor heating on and off. An illuminated LED signals that it has been switched on. If the main switch is pressed for a longer period of time (> 3 seconds) to deactivate the electric power supply, the floor heating will also be switched off.



The hot water devices (13) and the floor heating are 230V devices. These devices cannot be switched on and off if there is no mains connection or shore power supply.



15 Bluetooth connection

Press this key to activate or deactivate the Bluetooth connection.



⑩ LED luminous band (10 LED filling level display)



Fresh water tank

When this key ⑫ is pressed, the filling level of the fresh water tank is displayed in 5 steps.

- Left LED blinks: very little water or tank is empty
- LEDs 1 to 3 light up: Filling level approx. 25 %
- LEDs 1 to 5 light up: Filling level approx. 50 %
- LEDs 1 to 7 light up: Filling level approx. 75 %
- LEDs 1 to 10 light up: Filling level > 75 %



Battery management

(model- or series-specific/optional extra)

When this key ⑪ is pressed, the filling level of the battery on board is displayed in steps of approx. 10% each.



If a LiFe battery has been equipped by the manufacturer, the current battery voltage can be read out on the battery manufacturer's smartphone app. A Bluetooth connection is required for this. Please refer also to the separate battery manufacturer's operating instructions.

Charging status approx.	LEDs
0%	First LED blinks
10%	1
20%	2
30%	3
40%	4
50%	5
60%	6
70%	7
80%	8
90%	9
100%	10

Brief description of the integrated circuits/fuse circuits (model-specific / optional extra)

A	Submersible pump, fresh water tank, toilette, diverse 12V sockets, USB socket
B	Combi heating system, fan, antenna, refrigerator, multimedia system, LTE/GSM module
C	Lighting in washroom and kitchen
D	Lighting in bedroom, corner shelf, diverse LED luminous bands
E	Lighting in living room, corner shelf, bar, side panel seating bench, diverse LED luminous bands
F	Lighting in outer tent, awning lighting, socket in outer tent
G	Fuse G protects the circuits which are switched to the battery if there is no 230V shore power supply available (Combi heating system, radio steady plus, compressor refrigerator, LTE/GSM module, absorber refrigerator control current).

Description of external control panel (multi-switch) in bedroom (depending on model/layout/country-specific)

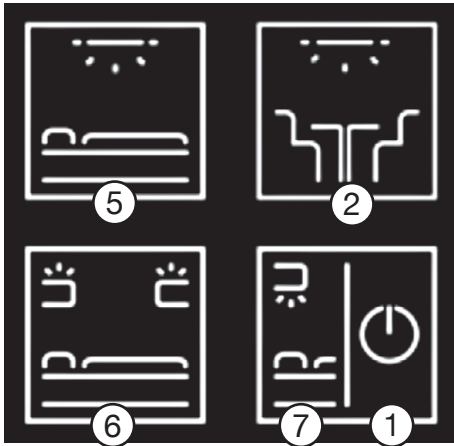

- ① Main switch (press for 3 seconds!)
- ② Switch/dimmer for ceiling light in living room
- ⑤ Switch/dimmer for ceiling light or LED strip - bedroom (depending on model/layout / country-specific)
- ⑥ Switch/dimmer for upper LED strip light for overhead storage compartment / ambience ceiling light in bedroom (depending on model/layout / country-specific)
- ⑦ LED strip lower roof storage box – bedroom

① Main switch

Pressing this key for a longer period of time (> 3 seconds) switches off all of the lighting circuits (D, E, F) in the living room and the bedroom. This will not switch off the 230V devices (therme/boiler, floor heating).

The main switching relay and, therefore, the fuse circuits A to C will also not be switched off. It is not possible to press this key so as to switch all of the lights on as they were before, i.e. it does not have the same function as the main switch in the master control panel.

② Switch/dimmer for ceiling light in living room

Press briefly on the key to switch the spots on the ceiling in the living room on and off. Press longer on the key to regulate how brightly you want the spots to shine.

⑤ Switch/dimmer for ceiling light or LED strip - bedroom (depending on model/layout/country-specific)

Press briefly on the key to switch the spots on the ceiling in the bedroom on and off. Press longer on the key to regulate how brightly you want the spots to shine. This button is not meant for the lighting in the air-conditioning system.

⑥ Switch/dimmer for upper LED strip light for overhead storage compartment/ambience ceiling light in bedroom

Press briefly on the key to switch the upper LED strip light for the overhead storage compartment or the bedroom ceiling light's ambience lighting on and off. Press longer on the key to regulate how brightly you want the spots to shine.

⑦ Switch for LED strip lower roof storage box – bedroom

Press this key to switch the LED strip on and off.

Description of external control panel (multi-switch) for the outdoor lighting (depending on model/layout/country-specific)

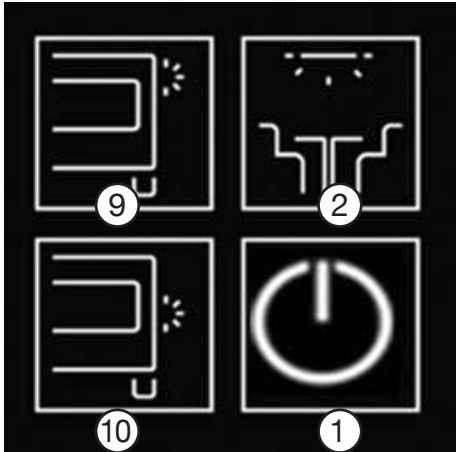

- ① Main switch
- ② Switch/dimmer for ceiling light in living room
- ⑨ Switch for outer tent light
- ⑩ Switch/dimmer for the light in the awning rail /
outer tent ambience

① Main switch

Briefly press on the “Main switch” key to switch off all of the lighting circuits (D, E, F). The state of operation of the lighting circuits will be saved when the main switch is switched off. Pressing the main switch again will switch the lighting circuits (D, E, F) back on. The circuits “230V floor temperature control system” and “230V boiler/therme” are not switched off automatically.

As long as the power supply has not been interrupted, the devices will then be in the same state of operation as before. Pressing the main switch for a longer period of time (> 3 seconds) switches the lighting circuits (C to F), the circuits for the floor temperature control system and the boiler/therme as well as the fuse circuits A and B off. This does not include the connection for the refrigerator and the heating system, nor the CP plus control panel. These devices always remain connected to the power supply.

Press the key  for approx. 9 seconds to switch all of the fuse circuits (A to E) on.

② Switch/dimmer for ceiling light in living room

Press briefly on the key to switch the spots on the ceiling in the living room on and off. Press longer on the key to regulate how brightly you want the spots to shine.

⑨ Switch for outer tent light

Press this key to switch the outer tent light on and off.

⑩ Switch/dimmer for the light in the awning rail/ outer tent ambience

Press this key to switch the LED luminous band on the awning rail or the lower light in the outer tent on and off. Press longer on the key to regulate how brightly you want these lights to shine.



Fendt Caravan Connect

In addition to standard operation, **Fendt Caravan Connect** enables most CI-BUS-enabled devices / components in the recreational vehicle to be operated via mobile devices (smartphone / tablet) as well. The free “**Fendt Caravan Connect**” app is required to be able to do this. The trailer (master control panel) is connected via Bluetooth.



The Fendt Caravan Connect app is only available for iOS or Android operating systems.



Android Operating System

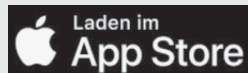

iOS Operating System



Only the current versions of these operating systems are supported. It may not be possible to install the app on older mobile devices.

The Fendt Caravan Connect app is constantly being further developed and updated. Therefore, new In-App functions are on offer from time to time.



Operating the Fendt Caravan Connect App



Descriptions and illustrations may vary, depending on the operating system of the mobile device.

Install the Fendt Caravan Connect app on your device and then start the app.

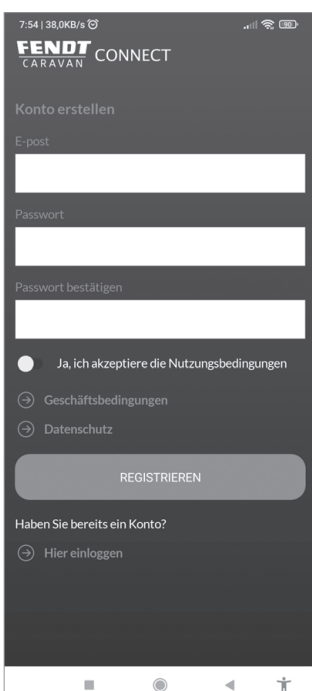

Start screen when accessing the app if a user has not yet been registered.

Register

You will be asked to register the first time you start the app. If registration has not yet been carried out, the registration interface will appear on the display.

Enter your e-mail address, your first and last name and set up a password. Activate the check box to confirm the General Terms and Conditions. Then click on “Register”. In the next step you will receive an e-mail, sent to the e-mail address you have entered. The mail includes a confirmation link. Click on the confirmation link to complete the registration process. In future, always enter this e-mail address and the selected password in the “Login” form.

When you have started the app, click on the Login button under “Do you already have an account?” to enter your login data (e-mail address and password).

7. Installation of electrical devices

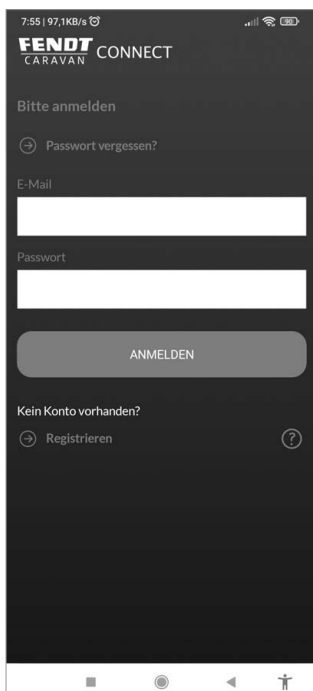

Login

Enter your e-mail address and password and then use the Login button to confirm the data you have entered.

Use the “Forgot password?” function to switch to a submenu and have a new password sent to the e-mail address entered.

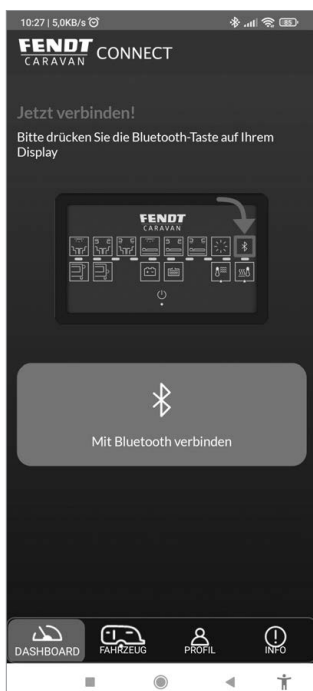

Selecting a connection

If the login data was entered correctly, the window for connecting to Bluetooth will open. Select “Bluetooth” to connect to your Fendt trailer.

7. Installation of electrical devices

Connecting Fendt Caravan Connect (Bluetooth)

To set up a connection between your mobile device and the control panel in the caravan, the Bluetooth function on both components must be activated.

Activate the Bluetooth function on your mobile device, refer to the device manufacturer's operating instructions if necessary, or you can set up the Bluetooth function manually in the settings.

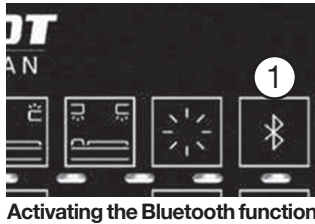

Activating the Bluetooth function

1. Activate the Bluetooth function on the control panel in the caravan. Proceed as follows:
Press the Bluetooth key ①.
2. Activate the Bluetooth function on your mobile device.
If necessary, use the manufacturer's operating instructions.
3. For the **initial** connection, the GPS function on the smartphone/tablet must be activated and permission given to access the app's location.



When the Bluetooth function has been activated by means of the key on the control panel, the LED luminous band will start to run for a predefined period of time during which it is possible to establish a link to the master control panel via Bluetooth.

Only one mobile device at a time can be connected to the app. If the app is to be used on another mobile device, it must first be disconnected from the device that is currently using it.

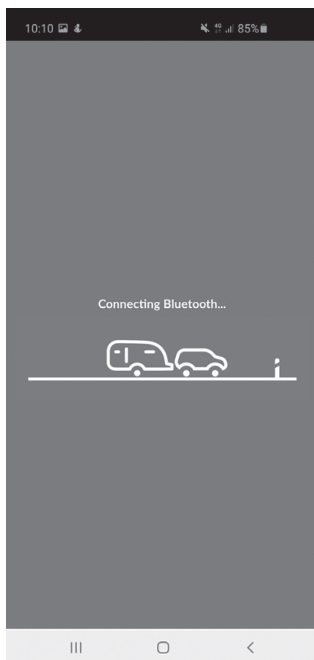

Connection is being activated

When the Bluetooth functions have successfully been activated, use the "Bluetooth" button on the app's Start menu to connect the components.



This procedure can take up to 30 seconds.

7. Installation of electrical devices

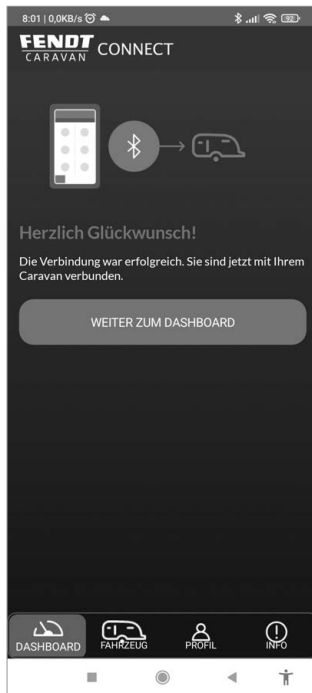

Successful Bluetooth connection

The successful connection of the Fendt Caravan Connect app via Bluetooth is depicted on the left.

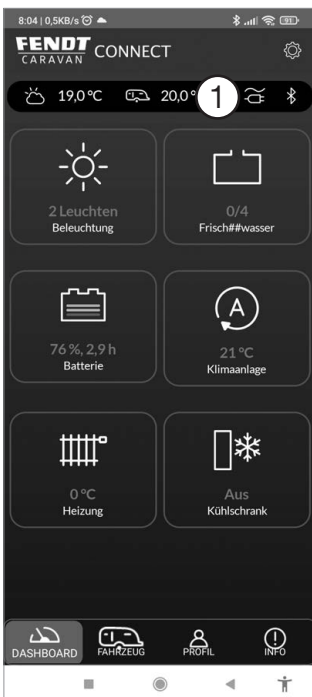

User interface

Using the app functions in the trailer (Fendt Caravan Connect)

The user interface shows the functions that can be read out and/or controlled via the app.



The operating elements on the app interface may vary, depending on how the caravan has been equipped.

Tap on the desired function once to enter the submenu and obtain detailed information on the function in question.

Descriptions and illustrations may vary, depending on the model and the operating system of the mobile device.

The temperatures outside and inside are displayed on the upper menu bar ① of the user interface. In addition, it can be read whether the caravan is connected to the 230V mains connection and whether the Bluetooth connection exists.



Descriptions and illustrations may vary, depending on the operating system of the mobile device.

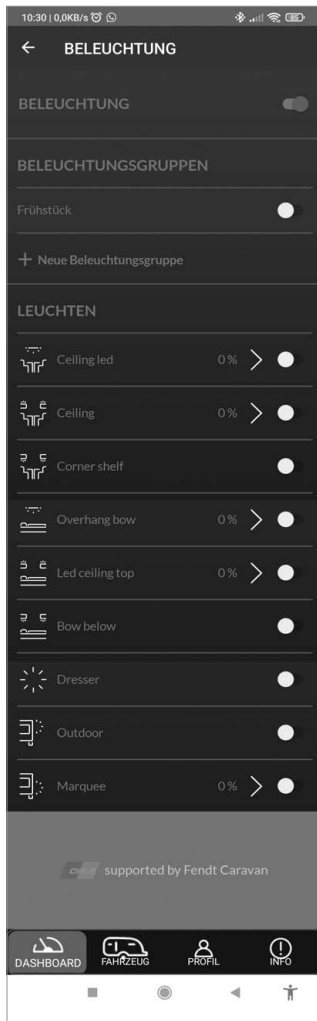

Lighting menu

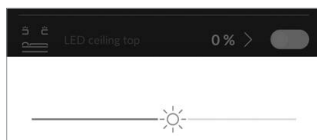

Dimming function

Lighting

Use the lighting menu to switch individual lamps on and off or dim them.



Battery Status

Battery status (for battery package 4 only) (model-specific, optional extra)

If the caravan is equipped with the battery package, the battery status will display the following:

- whether the battery is being discharged or charged,
- charge level,
- voltage,
- power,
- how much time the battery requires to be charged fully or how long the battery can continue to deliver power at the present current consumption,
- and whether the charge controller is connected to the 230V mains.



Please refer to Chapter 7.5, the separate battery manufacturer's operating instructions as well as their smartphone app.

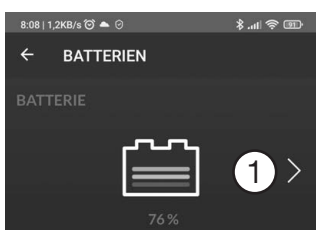

Battery settings

Use the arrow ① next to the battery icon to switch to this submenu.

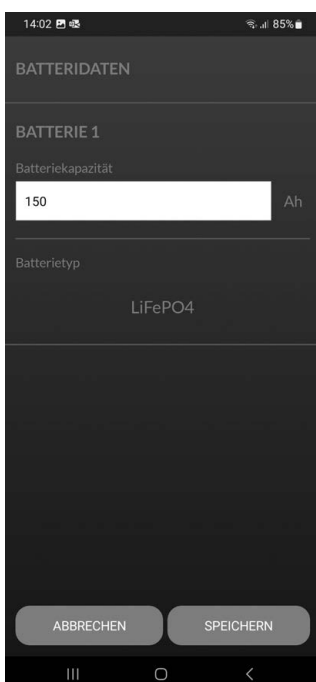

Battery settings

The following settings can be made and saved:

- battery capacity in Ah
- battery type

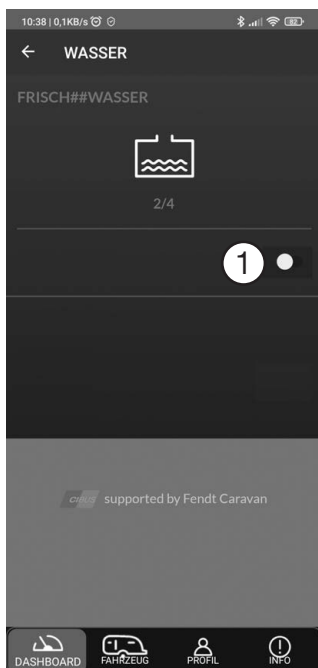

Filling level of the fresh water tank

Water Tank

The level indicator of the water tank shows how much fresh water is in the tank in steps from 0 (empty) to 4 (full).

For acoustic monitoring of the filling level, the slider button ① must be activated.

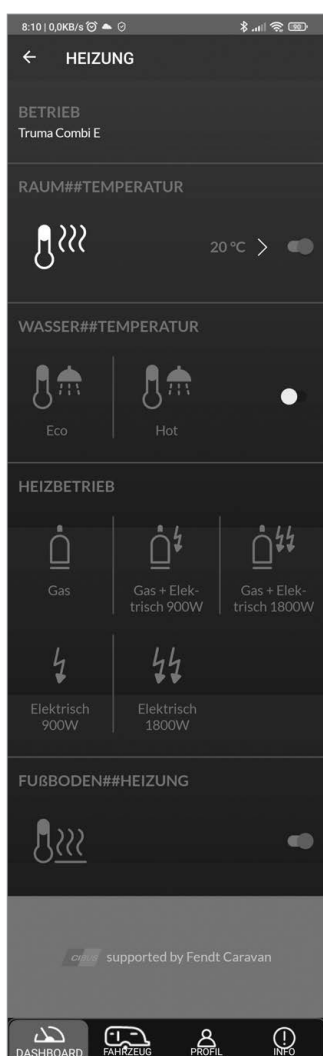

Heating

Heating

Click on the “Heating” icon on the menu to regulate/switch the temperature in the room and for the water on and off.

Depending on how the caravan has been equipped, this menu is used to regulate

- the heating
- and the floor heating system, and switch them on and off.

In addition, the hot water supply from the Combi or Alde heating system can be switched on and off, as required.

The desired room temperature can be set in steps of 1° C, from +5° C to +30° C.

Type of operation

Gas, mixed operation (gas+electric) or electric can be selected.

If mixed operation or electric operation have been selected, the desired performance must also be selected.

Truma: 1 lightning bolt = 0.9 kW, 2 lightning bolts = 1.8 kW

Alde: 1 lightning bolt = 1 kW, 2 lightning bolts = 2 kW and 3 lightning bolts = 3 kW



From a performance of 2kW or more, the power supply being fed in must be secured with a 16 Amp fuse. Please speak to the person operating the camping site!



The heating system can be controlled either via the Truma or Alde heating control panel or via the Fendt Caravan Connect app. It is not possible to control both systems simultaneously in parallel.

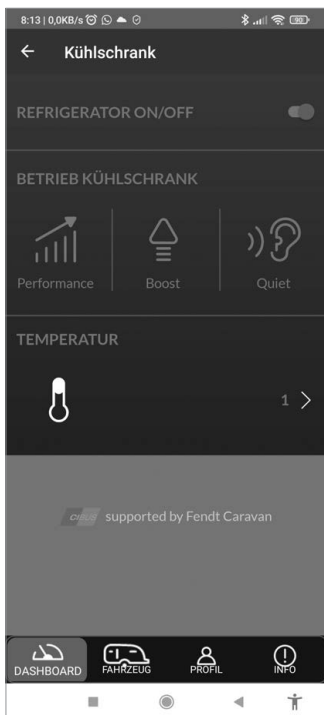

Refrigerator

Refrigerator (model-specific/optional extra)

Click on the “Refrigerator” icon on the menu to operate the device under different modes and to regulate the power / temperature.



The refrigerator operates in “quiet mode” for approx. 8 hours, after which it is automatically reset to “performance mode”.

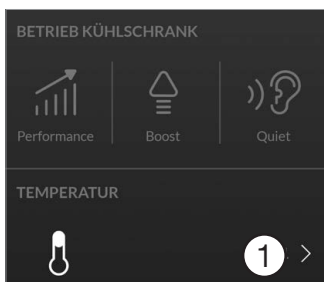

Refrigerator settings

Refrigerator settings

Use the arrow ① next to the temperature icon to switch to the sub-menu “Temperature settings”.



Temperature settings

The temperature can be set and saved here.



Air conditioning

Air-conditioning (model-specific/optional extra)

Click on the “Air-conditioning” icon on the menu to regulate/switch the temperature in the room.

Setting the temperature

The desired temperature can be set here (16 - 31° C).

This is not possible in air circulation mode, because neither the cooling nor the heating function are then active.

Setting the fan level

Depending on the type of operation, the desired fan level can be set here. When in automatic mode, the ventilation will also be regulated automatically, i.e. it is then not possible to enter a separate setting.

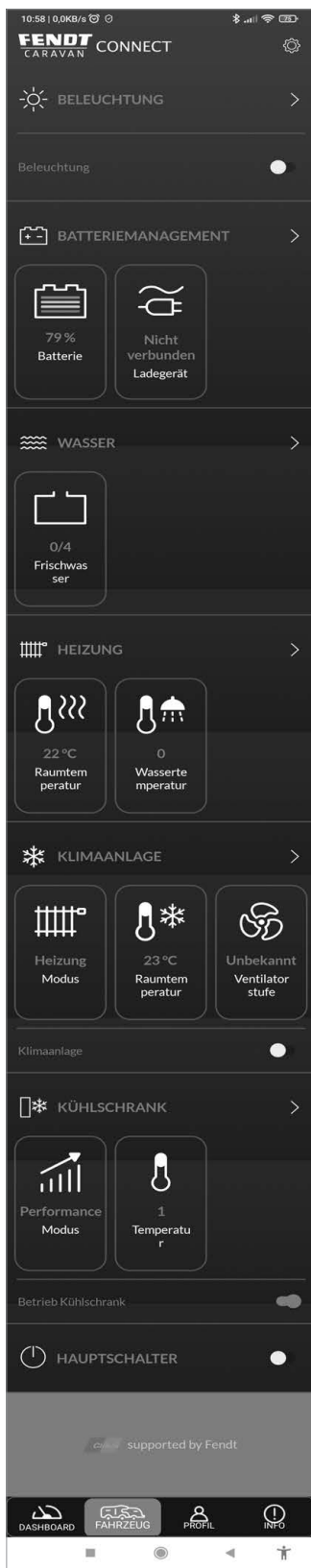

Overview of the vehicle

Overview of the vehicle

The overview of the vehicle gives an overall view of the predefined settings (depending on how the trailer has been equipped).

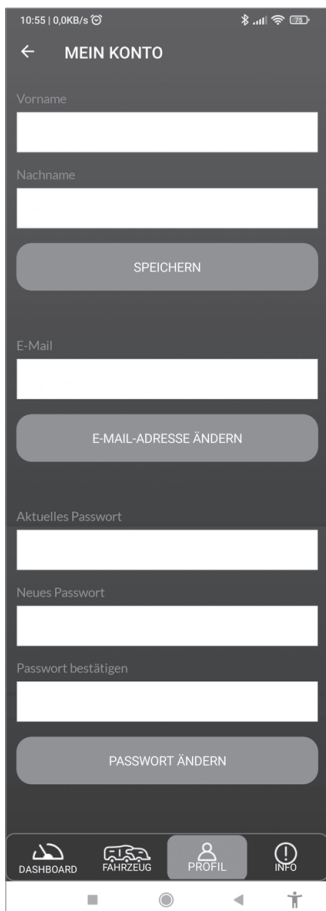

View of personal data

Profile/User overview

Personal data can be entered and/or amended in the Profile/User overview (name, e mail address, password).



Settings

Click on this icon (displayed on the left) at the top right of the user interface to access the settings overview.

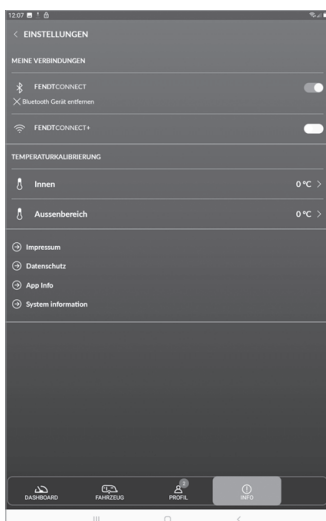

Settings

Here you can see whether there is a connection to the Fendt Caravan Connect app.

Click on the different submenus to obtain additional app information, read about the data protection regulations or check the legal notice.

The indoor and outdoor temperature sensor can be calibrated here should there be any deviations.

The current software status of the main control panel can be queried by clicking on the **“System information”** icon on the menu.

7. Installation of electrical devices

Possible problems

Possible problems	Approach	Other
The app cannot be found in the store.	Check the settings on the device; write Fendt-Connect as one word and not two.	Check the app settings in the respective country.
My mobile device will not install the app.	Only the current versions of these operating systems are supported.	It may not be possible to install the app on older mobile devices.
Bluetooth connection does not work.	Check the settings on your mobile device to ensure that Bluetooth has been activated.	Distance to the vehicle is too far.



Info menu

FAQs:

How can I connect the app to my vehicle?

Answer:

When first installing the app, you must register with your e-mail address and your password. Follow the set-up wizard to complete the first Bluetooth connection. An LTE or WiFi connection is required if you wish to reregister at a later date. We are currently working on an offline mode.

Can several users and mobile devices connect at the same time?

Answer:

Only one mobile device can be connected to the app at a particular time. If the app is to be used on another mobile device, it must first be disconnected from the device that is currently using it.



Further useful information on Fendt-Connect and answers to further topics can be found in the Info menu on the app.

The Fendt Caravan Connect app is available in the following countries:



7.5 Power supply using the Li-Fe battery package (model-specific/optional extra)



Li-Fe battery package 1 – 30Ah

Li-Fe battery packages 1 and 2 (optional extra in the APERO and BIANCO series)

If the camper was fitted with separate equipment and/or a battery package at the factory, the following must be observed:

In the nylon folder that contains the documents for the vehicle you will also find the following operating instructions and connecting diagrams:

- Manufacturer's user manual for the LiFe battery / charger/charge controller

Please read these important documents carefully to ensure that the battery package functions correctly and efficiently.

7. Installation of electrical devices



Li-Fe battery package 2 – 150Ah



This can only function correctly if the wiring and connections in the towing vehicle have been carried out/allocated according to DIN 72570.

If the battery package has been installed by the manufacturer, a LiFe battery is always used. Generally, depending on the layout, the battery can be found either in the wardrobe, the storage space in the seating arrangement or the bed base. LiFe batteries may not be replaced by a conventional wet battery.

Use a smartphone app to query the current charging state or the remaining power capacity of the LiFe battery on board. A Bluetooth connection to the battery is required for this.

The battery circuit breaker ① disconnects the battery from the 12V electric system.



If an electric manoeuvring system is subsequently installed, it must have its own circuit breaker.

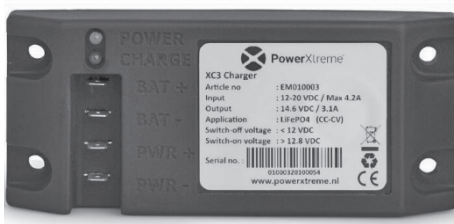

Charge booster



It is only possible to charge the batteries while driving by means of a charge booster for lithium batteries (optional extra).



Battery circuit breaker set to "0" OFF



Every battery has a self-discharge. Thus, it is important that **the battery is always fully charged before it is not used for a longer period of time (> 2 months). Then the battery circuit breaker ① must be set to 0 OFF and/or the positive pole on the battery (quick release) must be disconnected.**

Switch off all devices and lights before you disconnect the battery.

Please also note the label in the wardrobe.



Operating the refrigerator while driving: The 12V circuit breaker must be ON. Otherwise, the 12V electronic refrigerator will not be supplied with electricity and it is not possible to select the type of energy to be used (model-specific).



Li-Fe battery package 3 – 30Ah



Li-Fe battery package 4 – 150Ah



Li-Fe battery packages 3 and 4 (optional extra in the TENDENZA and DIAMANT series)

If the camper was fitted with separate equipment and/or a battery package at the factory, the following must be observed:

In the nylon folder that contains the documents for the vehicle you will also find the following operating instructions and connecting diagrams:

- Manufacturer's user manual for the LiFe battery / charger / charge controller

Please read these important documents carefully to ensure that the atark package functions correctly and efficiently.



It can only function correctly if the wiring and the connections in the base vehicle have been carried out/ allocated according to DIN 72570.

Operation using an auxiliary battery

If the caravan is not connected to the 230 V mains supply, the auxiliary battery will supply the electrical system with 12 V DC voltage. Since the battery only has a limited capacity, the electrical devices should not be operated for a longer period of time without charging the battery or connecting the caravan to the 230 V mains connection. The battery is charged via a 230V mains connection.

If the battery package has been installed by the manufacturer, a LiFe battery is always used. Depending on the layout, the battery can be found either in the wardrobe, the storage space in the seating arrangement or the bed base. This LiFe battery may not be replaced by a conventional wet battery.



Every battery has a self-discharge. Thus, it is important that **the battery is always fully charged before it is not used for a longer period of time. Then the battery circuit breaker ① must be set to 0 OFF and/or the positive pole on the battery (quick release) must be disconnected.**



Switch off all devices and lights before you disconnect the battery. Please also note the label in the wardrobe.

Description of the different displays on the master control panel or on the Fendt-Connect app



Please also refer to the information in this chapter on **Page 50 "Battery management"**.



If a Li-Fe battery has been equipped by the manufacturer, the current battery voltage can also be read out on the battery manufacturer's smartphone app. A Bluetooth connection is required for this.

Please refer also to the separate battery manufacturer's operating instructions.



- The installed battery may not be opened.
- When changing auxiliary batteries, use only batteries of the same make and capacity.
- Before disconnecting or connecting the auxiliary battery, disconnect the electric connection to the base vehicle and switch off the 230 V supply, the 12V supply as well as all electrical devices. Always connect the auxiliary battery first! Then connect the caravan to the 230V charging current.
- Before replacing fuses you must first de-energise the charger and the charge controller.
- Before replacing a blown fuse you must first fix whatever caused the fuse to blow.
- Fuses may only be replaced by fuses with the same fuse protection value.
- If the charger / charge controller are not ventilated sufficiently, the charging current as well as the life-span of the device will be reduced.
- The surface of the charge controller casing may become hot when the device is in operation.



- Before each journey, please check that the battery is charged. Where necessary, set up a mains connection so that the battery can be charged.
- Use every opportunity during your journey to charge the battery.
- The battery loses its capacity after having been used for a while and at low temperatures.
- If the remaining capacity of the LiFe battery is < 5%, all 12V devices will automatically be switched off.
- If the vehicle is not in use for a longer period of time, the battery should be disconnected or the main switch should be switched off after the battery has been optimally charged.

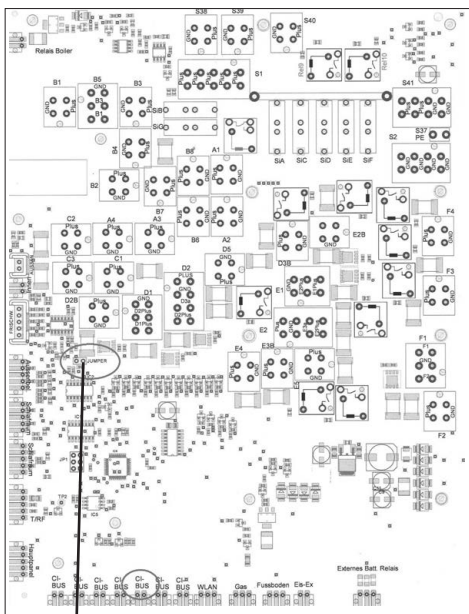

The "Jumper" ① setting must also be changed on the circuit board in the switch box if an independent system and a battery are installed in the trailer at a later stage. In self-sufficient mode, the bridge circuit must be connected to the two pins in such a way that both of them are electrically connected. When this conversion has been carried out, it is possible to operate all 12V devices during battery operation.



TENDENZA and DIAMANT:

When using the optional extra "Battery charger without battery", note that a I U₁ U₀ charging characteristic is stored in the charge controller (check that the charging characteristic of the charge controller is compatible with the battery manufacturer's charging characteristic).

APERIO and BIANCO:

When using the optional extra "Battery charger without battery", ensure that the types of battery stipulated by Dometic are used.

①

Jumper

7. Installation of electrical devices

General product information and safety tips for Li-Fe batteries



All models have a lithium iron phosphate battery (LiFePO₄ battery).

Apart from safety, the LiFePO₄ technology features the following characteristics, among others:

- low tare weight
- compact dimensions
- high efficiency
- very good charging cycle performance

It is possible to use almost 100 % capacity. After the capacity has been used up, the battery goes into sleep mode.



An essential element of a LiFePO₄ battery is its Battery Management System (BMS).

Both LiFe batteries are equipped with Bluetooth technology for monitoring the status of the battery by means of an app



Important safety tips

- Please read the user manual carefully before using the battery.
- Store the user manual near the battery and make it available to all users.
- Only technically qualified personnel may carry out work on the battery.
- The electrolyte is highly corrosive! Under normal circumstances, it is not possible to come into contact with the electrolyte. Should the battery be damaged, avoid direct contact with the electrolyte or the powder. Should someone come into contact with the electrolyte, rinse the skin immediately with lots of water and then contact a doctor.
- Use only cables with the correct diameter and keep the cable connections as short as possible.
- Never mix up or short-circuit the + and - poles.
- Never open the battery. The liability for material defects will immediately expire if the battery has been opened.
- Never mount the battery when it is damp or raining.
- Avoid damage to the battery and/or the charger.
- If the battery is stored for a longer period of time (> 2 months), ensure that it is fully charged.
- If the battery is stored for a longer period of time without being used, we recommend that it be charged once every six months.
- Never forget to disconnect the battery circuit breaker or the poles if the battery is not used for a longer period of time.
- Always used a charger suitable for LiFe batteries. This charger must be suitable for LiFePO₄ cell chemistry as well as the corresponding charging voltage.



Important! Using a charger which is not suitable for Li-FePO4 chemistry can damage the battery because it will not be properly charged.



Important transportation tips

- Before transporting a lithium iron phosphate battery, always check all of the applicable local, national and international regulations.
- In certain cases, transportation of a used, damaged or recalled LiFe battery may be restricted in special circumstances or prohibited.
- Transportation of a LiFe battery is classified in hazard class 9, “Miscellaneous Dangerous Goods”, UN 3480 “Lithium ion batteries”.
- When being transported by water, in the air or over-land, LiFe batteries fall under packing instructions P965.



User's manual: downloading the app – technical support

For PowerXtreme X30 Li-FePO4 batteries

The PowerXtreme app for mobile devices such as Android and Apple can be found in the Google Play Store or the Apple App Store. A QR code is available on the following website or on the label in the wardrobe.



<https://www.powerxtreme.nl/de/service>



For Super B Epsilon 12V 150Ah batteries

The Super B Be In Charge app for mobile devices such as Android and Apple can be found in the Google Play Store or the Apple App Store. A QR code can be found in the battery manufacturer's operating instructions or on the label in the wardrobe.



<https://www.super-b.com/de/support>

Recycling and disposal

Electric devices may not be disposed of in the container for normal household waste. In accordance with Directive 2002/96/EC of the European Parliament on waste electrical and electronic equipment, these devices must be collected separately to enable their environmentally friendly reuse.

Before disposal, always discharge the battery. Use insulating tape or another permissible means of covering the battery poles to prevent short-circuiting.

Dispose of lithium ion batteries in compliance with local, state and national laws and regulations. Turn in or send the battery to an authorised recycling centre. If in doubt, speak to your local authorities.

7.6 Circuit diagram for lighting in the vehicle 12V 13-pole



The colours of the individual wires may deviate.

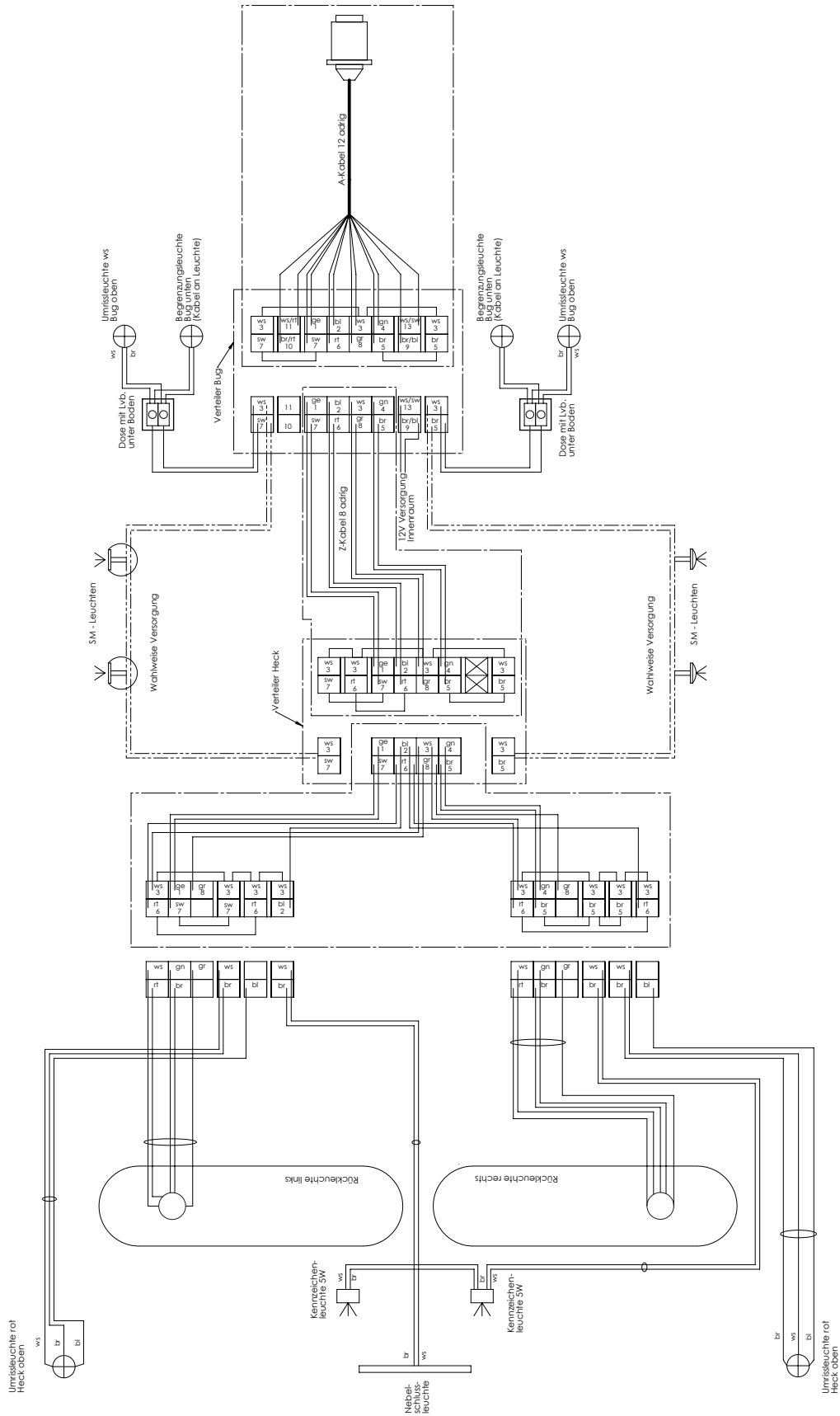

7. Installation of electrical devices

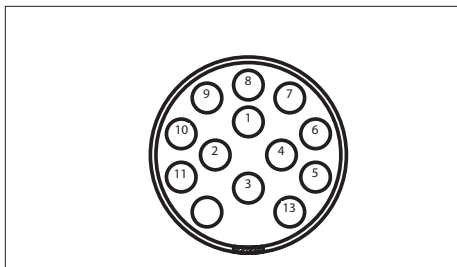

"Jäger" outlet (13-poled)

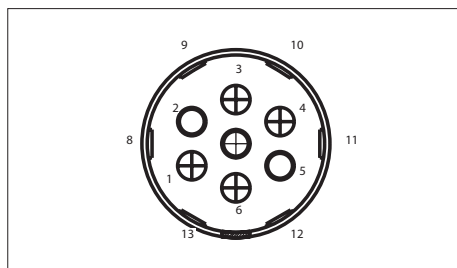

"Feder" outlet (13-poled)

Pin connections for sockets

No.	Colour	Electric circuit	Contact No. DIN	Cross-section mm ²
1	yellow	left blinker	L	1.5
2	blue	Fog tail lamp	54g	1.5
3	white	Earthing for 1-8	31	2.5
4	green	right blinker	R	1.5
5	brown	right rear light	58R	1.5
6	red	brake light	54	1.5
7	black	left rear light	58L	1.5
8	grey	back-up light	–	1.5
9	brown/blue	Steady plus	–	2.5
10	brown/red	Charging cable	–	2.5
11	white/red	Earthing for 10	–	2.5
12	–	free	–	–
13	white/black	Earthing for 9	–	2.5



For the 12V / 230V electrical supply, please refer to the separately enclosed circuit diagrams.

7.7 Lights in the caravan requiring extra switching



Outer tent light and awning lighting

The light in the outer tent is switched on and off using the double rocker switch next to the entrance door or the corresponding keys on the control panel of the light control system (**Chapter 7.4 model-specific**).



The outer tent light must be switched off when driving on public roads.



Children's bedroom light with USB connection (model-specific)



The USB connection is only used to supply power and for charging compatible devices such as smartphones or MP3 players.



Wardrobe light (optional extra, model-specific)



The wardrobe light has a rechargeable battery which can be removed. It must be recharged regularly using the USB cable included in the delivery package.

Awning lighting (model-specific)

The awning lighting is switched on and off using the double rocker switch or the corresponding keys on the control panel of the light control system (**Chapter 7.4 model-specific**).



The awning lighting must be switched off when the trailer is on the road.



Workspace APERO Connect



The lighting/electrical system for the desk workspace only works with a 230V external connection or independently via a power inverter (**optional extra**).

7.8 Electrical floor temperature control system (special accessory, model-specific)

The heater mat is located in the walking area of the floor. It is approx. 60 cm wide. The length and position of the heating mat(s) depend on the model/layout of the caravan. This heating system is not meant to heat the room; instead, it reduces the loss of heat via the floor.

Switching the electrical floor heating 24V on and off

The switch is integrated in the control panel for the light control system or located near the rocker switch for the hot-water heater.

Technical data

Voltage 24V~ from its own 230V/24V transformer.

Depending on the length of cable mounted, there is a power consumption of approx. 56 W/mtr.



To prevent local hot spots, do not place objects for a longer period of time on the floor if the floor heating system has been turned on. Do not drill any holes in the floor or screw in any screws.



Due to construction (the heating foil is glued under the PVC flooring) slight outlines may be visible. However, these are not noticeable under a fitted carpet (model/series-specific). The electrical floor heating is operated by means of the control switch marked with the appropriate symbol. Depending on the layout / type of vehicle, the transformer for the electrical floor heating is located either at the front or rear end of the vehicle. It must not be covered when loading the caravan.

7. Installation of electrical devices

**Danger: heat build-up!**

When it is in operation, the electrical floor heating must not be covered up in the middle of the storage space under the transverse seating bench.

The danger of overheating also exists outside the storage spaces. It can be caused by insulating objects or the use of unsuitable carpets/fitted carpeting.



The electric floor heating has been equipped with intelligent control electronics which are dependent on the outdoor temperature. The outdoor temperature sensor is located near the control electronics, underneath the flooring.



Although the electric floor heating has been equipped with intelligent control electronics which are dependent on the outdoor temperature, it is not meant to be operated permanently.

Switch the floor heating off whenever the caravan is not being used.

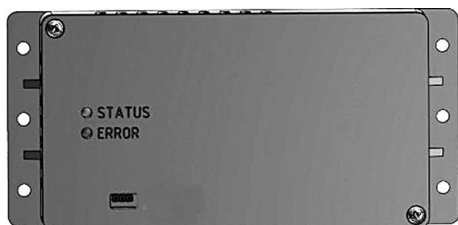

APERO / BIANCO



- The electric floor heating will not function if the outdoor temperature is higher than +23.5° C. The green LED blinks every two seconds.
- If the outdoor temperature is higher than +17° C and lower than +23.5° C, the intelligent control will switch to cycle mode: it will run in intervals of 20 min. ON, followed by 10 min. OFF. The green LED blinks at second intervals.
- If the outdoor temperature drops below +17° C, the system switches to “continuous operation”. The green LED is continuously lit. The heating is permanently active as long as the outdoor temperature is between -20° C and +17° C.

As a precaution, if the red Error LED blinks for several minutes or is continuously lit, switch the electric floor heating off. Before restarting, switch all the power in the caravan off by disconnecting the 230V shore power supply as well. If the red Error LED continues to blink or is continuously lit after restarting, turn the electric floor completely off (purely as a precaution) and before operating it again contract your Fendt dealer.

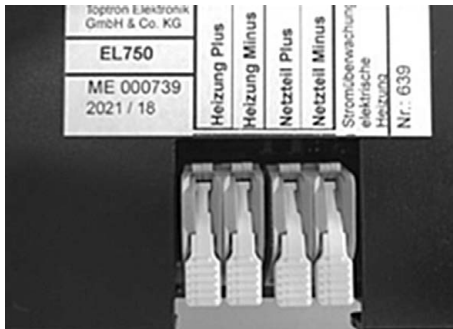

TENDENZA



- The electric floor heating will not function if the outdoor temperature is higher than +23.5° C. The green LED blinks briefly every two seconds.
- If the outdoor temperature is higher than +17° C and lower than +23.5° C, the intelligent control will switch to cycle mode: it will run in intervals of 20 min. ON, followed by 10 min. OFF. The green LED lights up at second intervals.
- If the outdoor temperature drops below +17° C, the system switches to “continuous operation”. The LED is permanently green. The heating is permanently active as long as the outdoor temperature is between -20° C and +17° C.

The LED is **green**:

The electric floor temperature control system is in operation. The electronic system monitors the electricity for the heating mat.

The LED is **red**:

Malfunction! Turn the electric floor heating completely off (purely as a precaution) and restart it.

Before restarting, switch all the power in the trailer off by disconnecting the 230V shore power supply as well. If the red Error LED is still lit after restarting, turn the electric floor heating completely off and before operating it again contract your Fendt dealer.

7.9 Microwave

(special accessory, model/series-specific)



Please observe the manufacture's operating instructions (enclosed).

7.10 Air-conditioning

(special accessory, model/series-specific)

Aventa compact
Aventa compact plus



DE Gebrauchsanweisung Im Fahrzeug mitzuführen	Seite 02	NL Gebruiksaanwijzing In het voertuig meenemen	Pagina 38
EN Operating instructions To be kept in the vehicle	Page 11	DA Brugsanvisning Skal medbringes i køretøjet	Sida 47
FR Mode d'emploi À garder dans le véhicule	Page 20	SV Bruksanvisning Skall medföras i fordonet	Sida 56
IT Istruzioni per l'uso Da tenere nel veicolo	Pagina 29	CS, EL, ES, ET, FI, HU, LT, LV, NO, PL, PT, RU, SK, SL	Page 67

truma
wärmen | kühlen | steuern
Mehr Komfort für unterwegs



Please observe the manufacture's operating instructions (enclosed).



(Only for assembly on the roof of the caravan): Installing an air-conditioner on the roof may have a negative influence on the trailer/driving performance of the caravan.



Not every caravan model (depending on the series/layout plan) is suitable for retrofitting a roof air-conditioning system. Your Fendt caravan dealer or service partner will be pleased to advise you.



The lighting integrated in the air distributor cannot be switched using the Fendt-Caravan Connect app.



7.11 Multimedia, Surf & Stream TV / Bluetooth amplifier

(special accessory, model/series-specific)



Please observe the manufacture's operating instructions (enclosed).



Excessive driving dynamic forces may occur when towing a caravan. We recommend that you remove the television from its mounting bracket when driving, stowing it if possible in the original box safely on or near the floor of the caravan.

7.12 Prewiring for antenna

The wiring for the antenna runs from the predefined position of the antenna mast (usually in the clothes cupboard) to the TV cupboard or to the predefined place for the television.

8.1 Water supply

General information

- Water that is suitable for drinking should always be used with working with food. This also applies to washing your hands and cleaning the objects that have come into contact with food.
- To ensure that the quality of the water is faultless, the water should be taken directly from the public drinking water system.
- Under no circumstances should garden hoses, watering cans and similar materials that are unsuitable for drinking water be used to fill the mobile system.
- If the caravan will not be used for a longer period of time, the entire water system must be emptied completely.
- After long periods of stagnation, the water system must be rinsed thoroughly before it is used again. If you find that it is contaminated, the material should be disinfected using cleaning agents that are permitted and suit-able.

Function of the water supply

Water is provided to the kitchen and toilet area via an immersion pump. The immersion pump functions on electricity:

- via a 12 volt automobile battery if the caravan is connected via a plug to the base vehicle,
- via a transformer if the caravan is connected to the 230 volt main.

Rules for the immersion pump:

- The immersion pump is only suitable for water.
- The immersion pump tolerates temperatures up to 60° C for a short time.
- Avoid dry runs.
- Protect the pump from freezing.
- Hard blows or hits as well as very dirty water can destroy the pump.



Rolling waste water tank

The rolling waste water tank ① can be pushed under the vehicle when parked; it collects waste water. It has a 24 liter capacity. The waste water tank can be transported with a fold-out transport handle to dispose of the contents at the designated stations.



During the trip, the waste water ② tank can be stored in the gas-bottle container to save space.

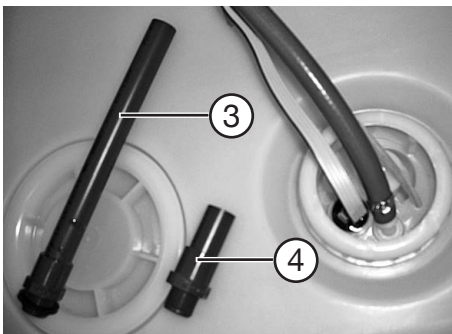
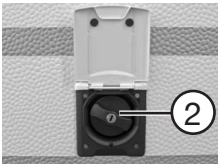

**Fresh water tank, 25 or 45 l
(model-specific, special accessory)**

The tank ① holds either approx. 25 or 45 litres. However, due to its design the actual amount of water may vary slightly.

The tank is filled with fresh water by means of the filler neck ② on the side wall.

The neck for filling up fresh water is marked by a blue cap and a picture of a water tap on the outer covering. The screw cap is opened and closed by means of the enclosed key for exterior flap locks and the door of the structure.

Should the tank overflow, the excess water is drained off underneath the vehicle by means of an overflow.

The water can be emptied from the tank by unscrewing the overflow pipe ③.



To optimize the payload, we recommend filling the fresh water tank with a maximum of 10 litres when driving. The caravan is equipped with an extra, short overflow pipe ④ to allow you to achieve this recommended amount.

8.2 Warm water supply via Truma-Therme



Rules for warm water supply:

- Only use water suitable for drinking.



Note the user's guide before first use!

To fill the therme:

- Open the warm water faucet or set the one-level mixer to "warm".
- Leave the faucets open until the Truma-Therme is filled by blocking the air and hot water flows.

To remove water:

- The water will be mixed to the desired temperature according to the position of the pre-mixing unit.

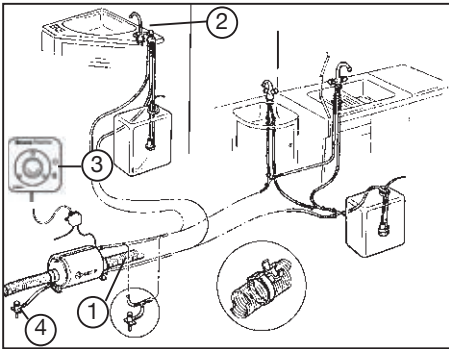

Plan for warm water supply

Emptying the therme:

- Turn off power by pressing switch ③.
- Use the main switch to switch the power for the water pump off.
- Open all of the water taps ② to the centre position.
- Open the drain valves ④ (rocker stopper).
2 drain valves are directly next to the therme; another 2 are on the opposite side.
- Check that the water is actually draining off.
- Shut the drain valves ④ before refilling the therme.

Electric operation:

- Use the switch ③ to turn on the therme. Use the thermostat to regulate the water temperature to approx. 55° C.
- Power consumption: approx. 300 W.

Rules for the therme:

- Switch the device off when the caravan is not being used.
- Empty the therme at the risk of frost. Frozen water can cause the therme to burst!
- A depressuriser must be used if the pump is connected to a central water supply, or on stronger pumps. The pressure in the therme may not exceed 1.2 bar. In addition, a safety valve or runoff valve ① must be used in the cold water tap.
- We recommend that you do not use the water from the therme as drinking water.



Never operate the therme electrically when it is empty.

WARNING:

The block circuit diagram only reflects the function. Due to the various floor plans, individual modifications are possible.



If your caravan was fitted with a TRUMA boiler by the manufacturer (see left illustration, model-specific, special accessory) please observe the manufacturer's operating instructions, included in this package.

Drain valves:

2 directly next to the boiler; another 2 on the opposite side (layout/model-specific).



If your vehicle has been equipped with a **TRUMA Combi heating system**, please note the information given in **Chapter 9 on page 90**.

8.3 Water taps

The water taps in the kitchen and bathroom have an integrated microswitch. When the mixer lever is raised, this switch activates the immersion pump in the fresh water tank.



Danger of damage caused by frost.

The entire water system must be emptied completely if the caravan is not in use during the frost period.

- Disconnect the power supply.
- Open the mixed lever on the water tap.
- Open all of the water draining valves (tilting or rotating valves) on the water pipes.
- Check to ensure that the water is actually draining off.
- Leave the mixed lever on the tap open in the middle position.
- The interior of the caravan must first be heated before filling and using the water system again during the frost period.

8.4 Cassette toilet (model/series-specific)



Picture may vary somewhat from the actual model.



Please observe the manufacture's operating instructions (enclosed).

In order to allow the toilet to be flushed when the caravan is parked it must be ensured that there is sufficient current and voltage.

In rare cases, the energy/battery management of some models of car may result in the base vehicle not having sufficient current and voltage. Please contact your car manufacturer's service partner for more detailed information.

9.1 General safety rules for the use of liquid gas facilities

Information on using the gas system for commercial purposes:

- The gas system in your trailer has been installed and inspected in accordance with DIN EN 1949 and DVGW/G 607 [German Technical and Scientific Association for Gas and Water] for liquefied petroleum gas (LPG) systems in recreational vehicles fit for habitation. It is not meant for commercial use.
- If the vehicle is to be used and operated exclusively or predominantly for commercial purposes, additional regulations apply. For example, additional safety stickers and a different gas pressure regulator are mandatory.
- The vehicle must be installed in accordance with DGUV [German Social Accident Insurance] Regulation 110-010 and inspected in accordance with DGUV 310-003. Please inform yourself about the currently valid situation for commercial use and approval at an authorised inspection centre.



The gas operation pressure is 30 mbar.

Inspection of the gas facilities

- Have the gas facilities checked by an expert before the first use.
- The gas facilities should be inspected by an expert every two years. This inspection should be documented on the inspection certificate in accordance with the German Association of Gas and Water Experts, worksheet G 607, and EN 1949.
- Regulator knobs, hoses and waste gas outlets should also be inspected.
- The safety regulator and hose lines must be replaced at least every 10 years.
- The owner/operator is responsible for arranging the inspection. This also applies for vehicles that are not licensed to drive on public roads.



Installations and modifications

- Located behind the kitchen drawer.
- Installations and modifications may only be conducted by an expert.
- Only devices with a uniform inlet pressure of 30 mbar may be operated.
- Any change in the gas facilities requires a new inspection by an expert and written documentation of this inspection.

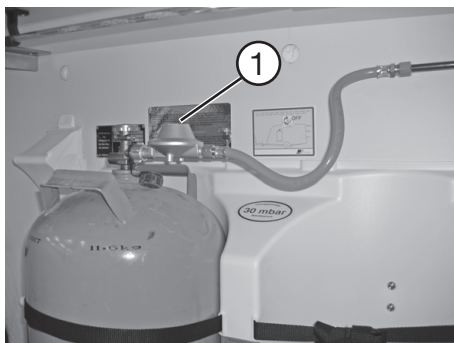

Picture may vary somewhat from the equipment on your caravan!

Regulator knobs and valves

- Only use those regulator knobs custom-made for vehicles, with a safety valve ①. Other regulator knobs are not permissible in accordance with the German Association of Gas and Water Experts, worksheet G 607, and EN 1949. They are not sufficient to tolerate the immense strain.



Connections on gas pressure regulators are screwed on counterclockwise.

- Pressure regulators must have a fixed output pressure of 30 mbar. The requirements of EN 12864, Appendix D, apply accordingly. The regulator must have a rate of flow of 1.2 kg/h.
- Connect the regulator knobs very carefully by hand. Do not use keys, pliers or similar tools.



Use the de-icing system (Eis-Ex) for the regulator knobs when the temperature drops below 5° C.

During the liquid gas manufacturing process oily residues in the form of aerosols may occur. These residues can impair or even damage the orderly functioning of the gas regulator(s) or the entire system.

Particularly for the optional extra “Truma-Duocontrol CS”, we recommend using a gas filter which is fitted in front of the gas regulators.

Before first use

- Ventilation openings should remain unobstructed.
- If necessary, remove snow from the flue and/or mount the flue extension.
- Remove any dirt and snow/debris mixture from the suction openings under the vehicle floor; otherwise, the levels of carbon monoxide could increase to dangerous levels.
- The safety ventilation openings may not be closed.
- We recommend that you keep a fire extinguisher that uses drying powder, with a capacity of at least 1 kg, by the entry door, as well as a fire blanket by the cooker. Ensure that everyone is familiar with the fire prevention measures on site (**see also 2.1 General information**).



Read the operating instructions from the manufacturer carefully.



Never use portable cooking or heating equipment, except for electrical heating equipment (**note the power consumption**), but not radiant heaters, because these may cause a fire or risk of suffocation.

9.2 Gas supply

The caravan is equipped with propane gas facilities. These facilities operate the following devices:

- cooker
- refrigerator (**model-specific**)
- heating element
- warm water boiler, if necessary
- special equipment, if necessary
- baking oven, if necessary

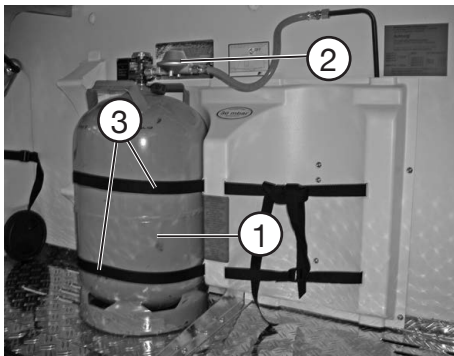

Bottle container

The gas-bottle container holds two 11 kg bottles of propane gas ①. The gas bottles are connected to the supply line by a safety regulator hose ②. Each bottle is fastened to the gas-bottle fixture by means of two belts ③.



Gas bottles may only be carried in the gas-bottle container.

Rules for the gas-bottle container:

- Before every trip, check that gas bottles are securely fastened. Place them in an upright position and shut the valves.
- Re-lash all loose belts.
- Using a leak indicator, inspect the regulator connection for leaks every time you change a bottle.
- The gas-bottle container is not suitable for transporting accessories (e.g. outer tent).
- The main shutoff valves on the gas bottles must always be easily accessible.
- The ventilation of the gas-bottle container (gap between the bottom of the bottle container and the front wall) must not be closed.
- Lock the gas-bottle container to prevent unauthorised people from obtaining access.



Gas bottles must be closed when-ever you are driving.



A special plastic inset (special accessory) must be used for 5 kg gas bottles.

Changing gas bottles



Never smoke or light open fires when changing gas bottles. After changing bottles, check whether gas is escaping from the points of attachment by spraying these with a leak indicator.

- Open the flap of the gas-bottle container.
- Shut the main shutoff valve on the gas bottle.
- Manually unscrew the gas pressure regulator and gas hose from the gas bottle (left-handed thread).
- Loosen the belts and remove the gas bottle.
- Put full gas bottle back in the bottle container.

- Lash belts securely.
- Manually screw gas pressure regulator and gas hose onto the gas bottle (left-handed thread).
- Close the lid of the gas-bottle container.

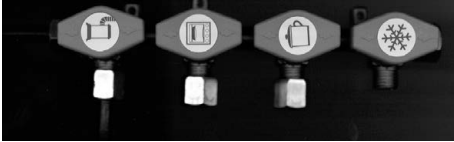

Number and assignment of the shutoff valves depends on the model and equipment you have; this may be different in your vehicle.

The symbols on the gas shutoff spigots have the following meanings:

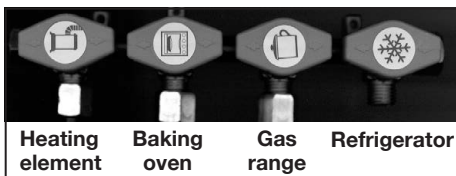

Shutoff spigots and valves

The gas circulation to the corresponding device can be cut off with these spigots. The spigots are marked with stickers for the corresponding devices.

Place of installation of gas shutoff spigots

- These are located in the kitchen in the upper drawer.

Rules for shutoff spigots and valves:

- Close all spigots on gas-powered devices during the drive.
- The gas shutoff spigots shown on the adjoining photos are closed. To open the valves, they must be turned to a vertical position.
- No inflammable devices may be in operation when filling the petrol tank of the base vehicle, on ferries and in the garage.



If you suspect a leak in the gas system, you must immediately close all the shutoff spigots in the caravan and the gas bottle valves in the bottle compartment.

If you suspect leaks, have your dealer or another expert inspect for leaks.

Such an inspection may never be conducted in the presence of open flames.

9.3 Hot-air heating



Heating element S 5004 and S 3004

(model/series-specific)



You are not permitted to operate the heating system while driving.

Exception: when using a licensed gas flow monitor (e.g. Truma-Duo-Control CS).

- S 5004
- S 3004

Place of installation

- In the clothes cupboard or chest of drawers.

Before first use

- Several air outlet nozzles have been built into the caravan. Pipes lead the hot air to the air outlet nozzles. Turn the nozzles so that the hot air is expelled where you want it.
- Check whether the flue is unobstructed. Any covers must always be removed.
- Before the first ignition, ensure that the batteries in the automatic ignitor are working properly.

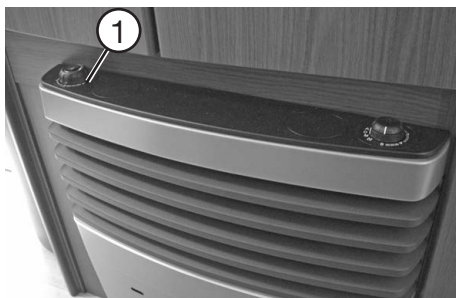

Pictures may vary somewhat from the equipment on your caravan!

Operation: (S 3004 / S 5004 with automatic igniter)

- Open the bottle valve and the quick-close valve in the gas line.
- Turn the operation handle ① to the thermo-stat position 1-5.
- Press the operation handle ① down until it locks. The ignition is automatic from this position, until the flame burns. The ignition spark is audible. The control light on the automatic ignitor ② blinks during ignition.
- Hold the operation handle in for up to 10 seconds, so that the ignition fuse kicks in.
- If the gas line is filled with air, it can take up to a minute until the gas is ready to burn. Hold the operation lever ① in during this period, until the flame burns.



Never re-ignite before 3 minutes have passed. Otherwise, there is a danger of deflagration! This also applies when the flame on an already operational heating element extinguishes and is reignited.



Please refer to the manufacturer's separate operating manual for detailed handling information.

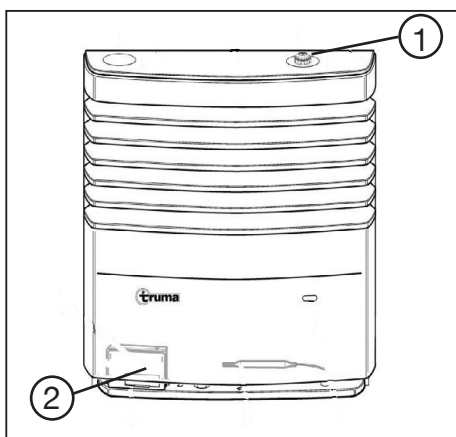

- If the flame extinguishes again, re-ignition takes place during the closing phase of the fusible cut-out of the ignition safety switch (approx. 30 seconds).
- If no flame is ignited, the automatic ignitor ② will continue to work until the operation handle ① is switched to "0".

To shut off:

- Turn the operation handle ① to position "0". The automatic ignitor is thereby shut off.
- Close the bottle valve and the quick-close valve if the unit is not used for a longer period of time.

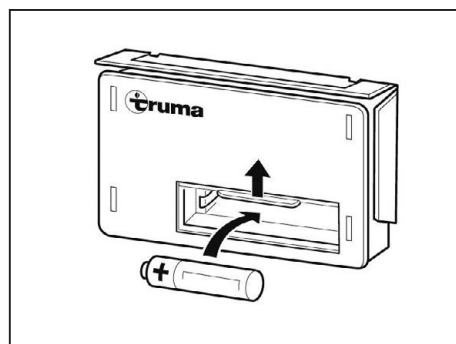

Changing batteries on the automatic ignitor

If you cannot hear any ignition sparks or only hear them in intervals of more than one second, then you must insert a new battery.

- Ensure that the heating has been switched off.
- Remove the radiator cover (see Truma operating instructions).
- Push the cover of the battery compartment up and exchange the battery (take special note of plus and minus).
- Close the battery compartment.
- Use only a temperature-resistant (+70° C) and leakproof minignon battery.



Insert new batteries before the beginning of each heating season.

Also note the separate operating instructions from the manufacturer.

Circulation fan



Picture may vary somewhat from the equipment on your caravan!

The heater in your caravan is equipped with a circulation fan. It circulates the hot air throughout the interior of the caravan.

Operation

The efficiency of the fan can be regulated by means of the switch integrated in the reflecting panel of the heater ① or by means of the external switch that is located near the heater.



If less air is circulated or the noise from the blower increases, this means that the ventilation wheel is dirty. As a rule, the heating element casing and vacuum pipe should be removed from the heating element approximately every 500 hours of operation and the ventilation wheel should be gently cleaned with a thin brush.

Please also refer to the manufacturer's separate operating manual.



For safety reasons, the spare parts for heating devices must meet the manufacturer's requirements and be fitted either by the manufacturer themselves or one of their authorised dealers.

Hot-water heating system (optional; not part of standard delivery)



Heating while driving is forbidden. **Exception:** when using a licensed gas flow monitor (e.g. Truma-Duo-Control CS).

The Compact 3030 LPG heater is a hot-water heating system which heats hot water separately (contents: 10 l). It is possible to heat up the heating system without filling the hot-water heater with fresh water.

The place of installation may vary, depending on the model and design.

Important information

- Please read the separate operating instructions carefully before initial operation of the heating system.
- Always turn off the main switch for the heating system whenever the vehicle is not in use.
- If there is danger of frost, always drain off the fresh water in the hot-water heater.
- You may not start the heating if the device has not been filled with glycol.
- To make the best possible use of the convection principle, the air must not be prevented from circulating throughout the caravan, e.g. behind the back cushions, winter ventilation slots, in the bed frame and behind the stow-age cupboards.

Modes of operation

- LPG operation
- Heating cartridge operation (230 V)
- Combined LPG and heating cartridge operation

Function modes

- Water heating
- Heating and water heating
- Heating



Check the level indicator of the glycol heat-transfer fluid. The system must not be started if there is no heating fluid or too little. Under normal operating conditions, the glycol heat-transfer fluid must be replaced at least every 5 years by an authorised specialist.



Operating device (see left illustration)



For further detailed information on operation, handling and maintaining the hot-water heating system, please refer to the separate operating instructions for “Alde Compact 3030”.

If the Alde control panel has been activated, parallel operation using the Fendt-Caravan Connect app is not possible.

Hot water floor heating

DIAMANT, BIANCO 720 SKDW / TENDENZA 560 SFDW and 650 SFDW models

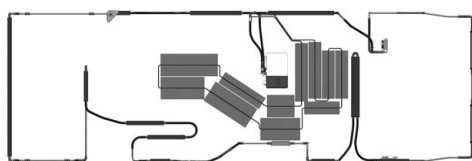

The hot water floor heating supplements the previously described Alde Compact 3030 hot water heating system.

The diagram on the left is merely an example to show how some of the heating plates have been laid.

The number and position of the heating plates differs according to the model and the layout of the caravan.



Holes must not be drilled nor screws wound into the floor, neither from above nor from below.

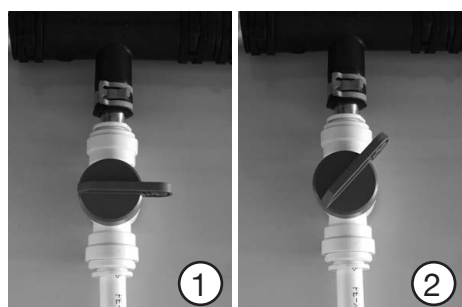

The flow control and thus the efficiency of the two water circuits (living room/bedroom) can be regulated by means of the shutoff valves.

One shutoff valve is located in the seating bench in the front (right-hand side in the direction of traffic) and one in the bedroom.

The photo ① on the left shows a shutoff valve that is closed.

The photo ② next to it shows the water circuit when it has been opened approx. 50%.

TRUMA-Combi C4/C6 (E) (model-specific/accessory)



TRUMA-Combi C4/C6 (E)

The TRUMA Combi fluid heater is a hot-air heating system with an integrated hot-water boiler that holds 10 litres.

When the heating and/or hot-water system is in operation, the room will be heated and, at the same time, so will the water. If only hot water is required, it is possible to operate only the hot-water system.

If you have selected the 'E' fitting package (model/series-specific; optional extra) the device also has additional heating rods for electric operation.



You are not permitted to operate the heating system while driving.

Exception: when using a licensed gas flow monitor (e.g. Truma-SecuMotion or Duo-Control CS).



Before first use

- Several air outlet nozzles have been built into the caravan. Pipes lead the hot air to the air outlet nozzles. Turn the nozzles so that the hot air is expelled where you want it.
- Check whether the flue is unobstructed. Any covers must always be removed.
- Open the bottle valve and the quick-close valve in the gas line.
- If necessary, fill the boiler with water.
- Use the control panel to switch the device on.



To start the device, the heating system must either be connected to a 230V power supply or 12V via the caravan's battery, should you be using a stand-alone power supply.

Please refer to the manufacturer's TRUMA[®] separate operating manual for detailed handling information.

Emptying the boiler



If the caravan is not being used when there is danger of frost or during the frost period, the boiler, contents of all tanks and water pipes must always be emptied.

- Switch off the electricity for the water pump.
- Open the hot water faucets in the kitchen and the bathroom. Place an appropriate container (10 litres) underneath the emptying support of the safety/outlet valve to check the amount of water that runs off.

- Open the safety/outlet valve. The boiler will now be emptied via the safety/outlet valve directly outside.
- Check to ensure that all of the water in the boiler has really run off via the safety/outlet valve.

Do not forget to open the other outlet valves for the water pipes. A further outlet valve is located directly by the Combi heating system. Two or three further valves (depending on the layout plan) are also located on the opposite side.

Warranty claims for damage due to frost can not be accepted!



When the temperature at the automatic FrostControl safety/outlet valve drops to approx. 3° C, it will open and the water will be emptied out of the boiler.

Maintenance

Only original TRUMA spare parts may be used for maintenance and repair work.

The device must be descaled regularly (at least twice a year).

We recommend using TRUMA's special products for cleaning, disinfecting and taking care of the boiler. Other products, especially those that contain chlorine, are unsuitable.

The chemical method used to control microorganisms in the device can also be supplemented by regularly heating the water in the boiler to 70° C.

9.4 Refrigerator



Please refer to the separate, enclosed Users' Manual provided by the device/product manufacturer  **Dometic** for useful information on operating and caring for the refrigerator.

In order for your refrigerator to function at 12V it must be ensured that there is sufficient current and voltage.

In rare cases, the energy/battery management of some models of car may result in the base vehicle not having sufficient current and voltage. Please contact your car manufacturer's service partner for more detailed information.

Only for Dometic 10 refrigerator series (absorber technology)



Continuous 12V current is required to operate the refrigerator self-sufficiently using gas.

Should your Fendt trailer not be equipped with a battery package, an external 12V power supply (which is not included in the scope of delivery) is required. An extension cord (**see photo on the left**) is provided as standard equipment to facilitate such a power supply.

However, this cable cannot be used to connect the original Dometic battery pack R10-BP, which is available as an optional extra.



Only a 9-12V power bank may be connected to this plug (Ø 2.5/5.5 mm) to operate the refrigerator self-sufficiently using gas.



Operating the refrigerator while driving when equipped with battery package 1 or 2:

The 12V main switch of the stand-alone power supply must be ON. Otherwise, the 12V refrigerator will not be supplied with electricity and it is not possible to select the type of energy.

Please refer to Chapter 7, page 66 of these operating instructions.



If the refrigerator is running self-sufficiently on gas, it must be switched off manually before refuelling.

Only for Dometic 10 refrigerator series (compressor technology) (model/series-specific)



The compressor refrigerator operates solely on 12V power. It gets the 12V voltage either from the built-in switching power supply (but only if there is a 230V connection) or directly from the car via the 13-pin plug while driving. However, this is only the case if the steady plus cable (pin 9) has also been assigned and is connected in the car.



If the refrigerator is not switched off during longer breaks in a journey it will drain the car's battery.

If, however, an additional battery has been installed in the trailer (optional extra) and there is no 230V connection, the refrigerator's current consumption will be drawn from this additional battery.

9.5 Gas cooker

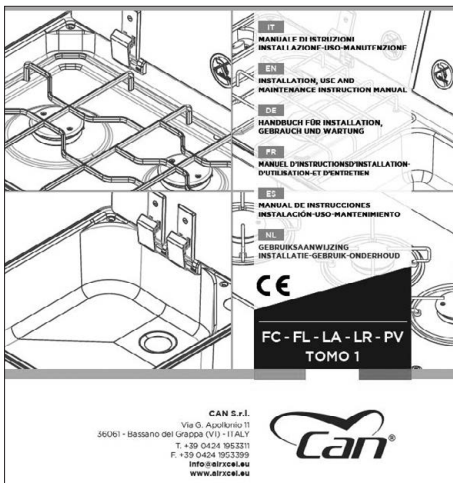

Please refer to the separate, enclosed Users' Manual provided by the device/product manufacturer, for useful information on operating and caring for the gas cooker.



When cooking, it is necessary to ensure that you have additional ventilation, e.g. by opening windows near the gas-operated grill, stove and/or oven. These appliances may not be used to heat the room.



There is an automatic cut-out feature on the cooker cover. When the cooker cover is shut, all of the hot-plates are switched off and the gas supply is cut off.



9.6 Oven



Please refer to the separate, enclosed Users' Manual provided by the device/product manufacturer, for useful information on operating and caring for the oven.



When cooking, it is necessary to ensure that you have additional ventilation, e.g. by opening windows near the gas-operated grill, stove and/or oven. These appliances may not be used to heat the room.

Accessories

Note the detailed operation instructions, installation instructions and circuit diagrams from the manufacturers when using accessories. These are located in your service package.

- Any changes to the status of the caravan as delivered by the manufacturer may endanger driving performance and roadworthiness.
- Any accessories, add-ons, modifications or mounted parts that have not been approved by Fendt may cause damage to the vehicle and impair its roadworthiness. Even if an expertise, general type approval or design approval has been provided for these parts, this does not ensure the orderly condition of the product.
- Fendt cannot accept liability for any damages caused by parts or changes that have not been approved by Fendt.
- In order for 12V devices (e.g. refrigerator, ATC, toilet flush, etc.) to function safely when driving it must be ensured that there is sufficient current and voltage.

In rare cases, the energy/battery management of some models of car may result in the base vehicle not having sufficient current and voltage. Please contact your car manufacturer's service partner for more detailed information.

The following table includes a list of weights for accessories. If these parts are carried in or on the caravan and are not included in the standard scope of delivery, they must be taken into consideration when determining the full load. These weight details are meant only as a guideline. They may vary slightly, depending on the model and equipment.

Object	Weight (kg)	Object	Weight (kg)
Additional single bed with cushions	11.0	Hot water boiler, 10 l, gas / electric	5.2
Aluminium fibre roof (with improved hail protection)	23.0	Hot water heating C 3030 HE (ALDE)	30.0
Anti-theft device "Fullstop", mechanical	5.0	Manoeuvring system "Mover XT" (Truma)	29.0
ATC Trailer Control	4.5	Microwave 12.0	
Battery package with 150Ah Li-Fe	19,5	Roof air-conditioning system "Aventa compact plus" (Truma)	31.0
Bicycle carrier "Superb SV", for 2 bicycles	9.5	Roof awning Omnistore 6300, 4.0 m long	43.0
Bunk bed (third bunk bed)	15.0	Screen door	5.0
City water pipe hook-up with 45 l fresh water tank	4.0	Skylight (280x280 mm) washroom	1.5
External storage compartment 749 x 297 additional	2.0	Spare tyre with steel rim, incl. mount	22.0
Fitted carpet, looped	9.0	"Stabilform" corner steadies, galvanised with "Big-Foot"	2.0
Flat screen TV, 61 cm	4.2	Temperature control of floor, electric	7.5
Fume hood 12V	3.0	TRUMA electric auxiliary heating "Ultraheat"	2.0
		TV mount "Sky"	3.5



The values given for the weight are average values; they may vary depending on the model and the features. To determine your vehicle's exact capacity for additional loads we recommend that you visit a nearby calibrated lorry weigher.

11.1 Maintenance

All of the information and recommendations for technical applications in this chapter are given to the best of our knowledge; however, they are not binding, especially with regard to any third-party industrial property rights.

This information / these recommendations do not exempt you from checking yourself. We cannot make any guarantees, because applications are beyond our control.

In case of doubt, please first test cleaning and care products in an inconspicuous area to determine their suitability.

Your Fendt caravan dealer will also be pleased to provide you with competent advice if you have more detailed questions.

Maintenance intervals

Fixed maintenance intervals apply to the caravan and the devices installed in it.

Rules for maintenance intervals

- Have the first maintenance performed by a Fendt dealer 12 months after the initial registration.
- Have all further maintenance performed once a year by a Fendt dealer.
- Have all maintenance on built-in devices performed in accordance with the corresponding maintenance intervals indicated in the operating instructions.



Fendt grants a 12-year guarantee on the absence of leaks in the caravan in accordance with the guarantee conditions. In order to maintain the guarantee, the vehicle must be taken to your Fendt dealer every 12 months. Tests for leaks must be carried out every 12 months. A fee will be charged for this test.



The inspection of the gas facilities (subject to extra cost) is to be repeated every two years by a liquid gas expert. This inspection is to be conducted and certified in accordance with the German Association of Gas and Water Experts, worksheet G 607 and EC 1949. The operator is responsible for scheduling this inspection in good time.

Replace safety regulator knobs and hoses no later than every 10 years!

Greasing and oiling

Check and oil the movable and stationary parts of the vehicle at regular intervals. If the caravan is used seldom, yearly maintenance is required.

Rules for greasing and oiling

- Grease the bearing spaces on the casing of the overrunning system.
- Oil movable parts such as bolts and joints.
- Grease the movable parts of the overrun coupling.
- Check to see that the stationary parts of the shearing rod are not jammed.
- Clean and oil all movable and stationary parts at regular intervals.



Please observe the maintenance and care tips in the separate operating instructions for the axles, overrunning equipment and anti-sliding coupling.

11.2 Ventilation

Sufficient ventilation and de-aeration of the vehicle interior is essential to maintaining a comfortable climate.



The oxygen in the vehicle interior is used up by passengers' breathing and the operation of gas-fuelled devices. It must thus continuously be replaced. Forced ventilation systems (e.g. roof bonnets with forced ventilation; mushroom fans or floor vents) have been fitted in the vehicle for this purpose. Forced ventilation systems may not be covered or blocked, either from the inside or from the outside. They must always be kept free of snow and leaves. Increased CO² levels can result in suffocation.

CHECK LIST:

- ✓ **Ventilate the caravan regularly!**
At least twice a day for 5 – 10 minutes each time
- ✓ **Always open windows fully when ventilating;**
cross-ventilation is best
- ✓ **Do not ventilate for long periods,**
instead ventilate often
- ✓ **Always wipe away condensation immediately**
- ✓ **Ensure that forced ventilation systems are never obstructed**

Using only the forced ventilation systems as the sole source of ventilation for the vehicle interior is, however, never sufficient.

Correct ventilation is thus just as important as correct heating. Moisture can occur anywhere in the interior – for example as result of showering, cooking, drying washing or simply passengers' perspiration.

Correct ventilation means regular ventilation – at least two to four times a day for 5-10 minutes each time. Moisture occurs in all living areas. Up to 12 litres of water can accumulate each day in a four-person household and this moisture must be disposed of by means of correct ventilation. Failure to do so will result in the moisture collecting in the coldest areas as condensation. This is the basis for mould, particularly in winter. A correct amount of fresh air is required to maintain a healthy, pleasant indoor climate.

Cross-ventilation of rooms is a particularly effective way of replacing air. Simultaneously fully open several windows; the door; the roof bonnets and, where applicable, the room dividers several times a day for several minutes. This will result in an air current which draws moisture from the inside of the caravan to the outside.

In contrast, permanent ventilation by means of windows which are only tilted or slightly opened is absolutely incorrect as the exchange of air is minimal and insufficient.



In some weather conditions even if you ventilate correctly condensation may settle on cold objects (e.g. metal fittings or fixings).

Thermal bridges (cold/warm) may occur at external openings (e.g. mushroom fans, roof bonnet edges, plug sockets, windows, filler pipes, flaps, etc.).

Always wipe away condensation immediately.

The relatively small room volume in recreational vehicles; the carrying in of damp clothing; breathing and perspiration as well as the operation of gas-fuelled devices can increase the formation of condensation.



In order to avoid damage caused by condensation you should thus – as described above – ensure that there is a sufficient exchange of air. You should also ensure that any ventilation slots/openings in overhead stowage compartments and / or in the stowage areas in seating and sleeping areas are not obstructed.

This is the only way to prevent condensation and, as a result, mould forming in unfavourable weather conditions. When heating, air distribution and ventilation are all coordinated with one another it is possible to achieve a pleasant room climate at any time of the year.

Do not make any alterations to the standard hot-air system. Do not turn off the system's circulation fans in the winter months, even at night.

Make sure that vehicle is occasionally ventilated even when it is not moved for some time; in summer there is a risk of heat accumulation. When ventilating be sure to also ventilate the externally accessible stowage areas as well as the interior space. Even if the vehicle is parked in a closed room (e.g. a garage) you must still ventilate it regularly.

11.3 Upkeep

Cleaning the exterior



Only wash the vehicle at specially designated wash sites.

Use cleaning solvents as sparingly as possible. Aggressive cleaners such as rim cleaner pollute our environment.



Do not use cleaners which contain solvents.

Rules for cleaning the exterior

- The vehicle should not be washed more often than necessary.
- Rinse the vehicle with a light stream of water.
- Wipe the vehicle down with a soft sponge and typical shampoo solution.
Rinse the sponge often in the process.
- Afterwards, rinse with a great deal of water.
- Dry the vehicle with a suede cloth.
- Allow the vehicle to stand out in the open after washing to let it dry.



Cleaning should be carried out regularly in coastal regions (less than 1500 m away from salt water), but at least twice a year.

Moss is also acidic and may damage surfaces. Here again, we recommend that affected surfaces be thoroughly cleaned at least twice a year.

Dry spotlight and lamp frames thoroughly, since water can build up in these areas very easily.

Do not use aggressive cleaners or cleaners which contain solvents.

Cleaning the roof

It is not possible to walk on the roof of the trailer. No liability is assumed for any damages resulting from such actions. There is an increase in the danger of slipping or falling if the roof is damp or wet. To clean the roof, we recommend using a washing station with an accessible lifting platform.

Cleaning with a high-pressure cleaner



Labels and exterior decorations should not be sprayed directly with a high-pressure cleaner, because they may come off.

Note the instructions for the high-pressure cleaner before washing the caravan with it. Keep a minimum distance of 700 mm between the caravan and the high-pressure nozzle.

Note that the water jet comes out of the cleaning nozzle with a great deal of pressure. Incorrect use of the high-pressure cleaner can damage the caravan. The temperature of the water must not exceed 60° C. Keep the water jet constantly moving during the entire washing process. The water jet must not be aimed directly at the clearance between the door frame and door leaf or the window frame and window leaf, electrical add-ons, pin-and-socket connectors, gaskets, sealing grill for refrigerator or the roof bonnets. This can damage the vehicle or allow water to seep into the interior.

Do not use a high-pressure cleaner to clean the rear lights of the caravan. The water can be sprayed under the rubber seal of the lamp and get into the lamp compartment. This delays drying time while increasing the danger of corrosion or the formation of moss.



Cleaning and care of plastic parts PS / ABS-PMMA (e.g. lamp supports, gas-bottle container, hub caps, shower tub, windows, LFI front wall, etc.)

Unsuitable cleaning solutions and stickers may cause possible damage to plastic parts.

Various media may cause stress cracks (fractures in parts), softening or swelling that can impair the function of the parts or even make them unusable.

Recommended manual cleaning

- Warm water (up to 60°C) to which a weak (2%) acid, alkaline or neutral commercial household cleaner can be added.

- Plastic cleaner, cockpit spray (NB: this may affect the glossy shine)
- If limescale has built up on the surfaces of the moulded parts, it can be removed using diluted acids such as acetic acids. To prevent scratches, avoid mechanical removal.



The following cleaning/care products may not be used for ABS/PMMA surfaces:

- In a highly concentrated form, alcoholic or alcohol-based cleaning agents can quickly lead to stress cracks. Irreparable damage may be caused even if the surfaces are treated incorrectly only once. Alcohol can be found in all alcoholic medication, facial toners, aftershaves, hair lotions, perfumes and similar kinds of products.
- Furthermore, cleaning agents that contain abrasive additives may also not be used.
- For example, of the chemicals generally found in households, the following should not come into contact with the PMMA surface: stain removers, iodine tincture, nail polish/nail polish remover, acetone, white spirits.
- You should also avoid exposure to oxidizing agents used for disinfection, such as ozone. Normal household toilet cleaners or similar disinfectants can also cause considerable damage to this material.

Direct contact with plastics such as PVC, soft PVC and similar products (e.g. stickers) must be avoided at all cost.

It is not possible to avoid transmitting plasticizers when solvent-based contents come into contact with the aforementioned plastics and this causes the parts to become brittle.



Do not use rubber bath mats or carpet flooring for the shower tub in the sanitary compartment that is unsuitable for PS/PE plastic. The contents of the carpet backing can cause the material to become brittle and lead to cracks. We recommend that you use the original Fendt caravan washroom carpet that is available as a special accessory.

The following applies when waxing varnished or painted surfaces

- Treat the paint surfaces periodically with wax.
Note the guidelines for use from the wax manufacturer.

The following applies when polishing varnished or painted surfaces

- In exceptional cases, treat damaged paint surfaces with polish. We recommend using solvent-free polishing paste for new varnish or paintwork. Before using the polish, test it first in an inconspicuous place.



Do not polish too often since polishing removes the top layer of paint. Frequent polishing causes more damage than it remedies.

The following applies for GRP surfaces:

To maintain the gel coat layer on GRP parts for as long as possible, we recommend that surfaces be polished regularly and then applying a protective wax coating. Depending on the duration and intensity of the sunlight, these measures should be repeated at least every three years.

Rules for damage repair

- All damage should be repaired immediately to avoid further damage from corrosion. Consult your Fendt dealer

Hot-dip galvanised chassis

Should salt adhere to the hot-dip galvanised chassis, it will damage it and may cause white rust. However, so-called “white rust” is not a defect, but merely an optical impairment.

The most frequent causes for white rust are:

- gritting material and road salt (e.g. when driving during the winter months),
- condensation, e.g. because the vehicle has been covered with plastic film or sheets),
- moisture (e.g. because the vehicle has been parked in high grass, puddles or mud),
- snow (e.g. when the vehicle is left to stand for a longer period of time in snow),
- lack of ventilation (e.g. when the undercarriage is covered with an apron).

We recommend the following procedure for preventing the build-up of white rust or removing any white rust:

- After driving in winter, rinse the hot-dip galvanised surfaces with clear water.
- If hot-dip galvanised parts are covered in white rust, treat these parts immediately with a zinc cleaner such as “Poligrat”.

Undercarriage

The undercarriage of the caravan has been coated with special underbody protection. If the protective underbody coating is damaged, repair it immediately.



Use only products that have been recommended by the manufacturer for this purpose. Our authorised partners and service centres will be pleased to advise you.

Window panes made of acrylic glass

Panes made of acrylic glass require particularly careful treatment.

- Never rub acrylic glass window panes dry, because dust particles may damage the surface.
- To clean acrylic glass windows, use only a generous amount of hot water, some dishwashing liquid and a soft cloth.
- Never use a glass cleaner with chemical or scouring additives or ones that contain alcohol, because this would cause premature brittleness and lead to cracks in the panes.
- Never drive through a car wash.
- After cleaning the vehicle's acrylic glass window panes, rinse them off with lots of clear water.



Finish off the cleaning process by using an acrylic glass cleaner that has an anti-static effect. Small scratches may be treated with acrylic glass polish. Such products are offered by accessory dealers.

Please also refer to the separate User's Manual provided by the device/product manufacturer,  Dometic for useful information on the care of the doors and windows.

Cleaning the interior

Rules for cleaning seat covers, upholstery covers and curtains

- Clean seat covers with a soft brush or vacuum cleaner.
- Have heavily soiled upholstery covers and curtains dry cleaned; do not wash them yourself!
- Clean with the foam of a gentle detergent if required.
- Cushion covers must not be taken off the foam core of the cushions.

Rules for cleaning the carpet

- Clean with a vacuum cleaner or brush.
- If necessary, treat or shampoo with carpet foam.

Rules for cleaning PVC surfaces



Sand and dust can damage the surface of a PVC surface that is walked on regularly. When in use, clean the floor daily with a Hoover or broom.

- Clean the surface with a special solvent for PVC surfaces. Do not place carpets on wet PVC surfaces. Carpets and PVC surfaces could stick together.
- Never use chemical cleaners or steel wool, because they will damage the PVC surface.

The following applies for furniture surfaces

The furniture fronts in some of the models have an acrylic surface with a brilliant deep sheen. The treatment and cleaning of these surfaces should match their beauty. We recommend using only a soft, damp cloth and a mild soapy solution for cleaning these surfaces.

Alternatively, to reduce static electricity, an anti-static plastic cleaner suitable for acrylic surfaces can be used. In this case, there is no need to first clean the surfaces with a soapy solution.



Under no circumstances should you use solvent-based intensive cleaning agents or alcohol-based cleaning agents (which are often found in typical glass cleaner products). The surfaces may be irreparably damaged even if they are treated incorrectly only once.



Do not use scouring agents or scrubbing sponges, because they will scratch the surface or leave an unnatural shine.

Maintenance tips for mirror surfaces

To ensure the long-lasting use of your new mirror, please observe the following important information.

Spots which occur during daily use (drops of water, toothpaste spatters, etc.) should best be removed with a soft cloth or your towel after you have dried your hands. Stubborn spots such as cosmetic smears may be wiped off carefully using a slightly damp microfibre or chamois cloth. If possible, the mirror should be cleaned without water and cleaning agents to ensure that dampness and/or chemicals do not penetrate the mirror coating. If, despite this, the peripheral area of the mirror should nevertheless become wet, dry it off quickly. If, after showering, the mirror should be fogged up, wipe the edges immediately to prevent corroding around the edges. For helpful tips on airing, please refer to **Chapter 11.2**.

Never use acidic bathroom cleaners, glass cleaners, all-purpose cleaners or window cleaning agents because they accelerate corroding around the edges of the mirror.

Rules for cleaning the toilet area

- Clean with neutral liquid soap and a nonscouring cloth.
- Do not use a vinegar concentrate to clean the toilet and the water system or to decalcify the water system. Vinegar concentrate can damage gaskets or parts of the system.



Do not use scouring cleaners in the toilet area either!

Do not pour corrosive cleaners down the drain. Do not pour boiling water down the drain. Corrosive cleaners and boiling water will damage the drainpipes and siphon traps.

Stainless steel wash basin/kitchen sink / INOX

- Clean wash basins and sinks with normal mild household cleaners or special stainless steel cleansing agents.
- Never use bleach, products that contain chloride or hydrochloric acid, baking powder or silver polish as a cleaner.
- Do not use scouring powder and/or household sponges with steel wool.
- If in doubt, use the cleaner first in an unnoticeable place to check whether or not it is suitable for cleaning the surface in question.
- After cleaning, dry all surfaces thoroughly with household wipes to prevent water stains and lime build-up.



Wash basin made of sanitary acrylic (accessory / model / series-specific)

Various trailer models / series have been fitted with a wash basin made of high-quality sanitary acrylic.

To ensure that you will enjoy this exclusive feature for a long time, the following instructions from the manufacturer for cleaning and care must be observed.

- First, use sufficient water to wash away any coarse or granular dirt (e.g. sand).
- Clean the surface with a clean, damp sponge and a bit of de-greasing household cleaner / dish washing liquid that does not contain any regreasing substances. Rinse with lots of water and then wipe dry with a soft cloth (e.g. a dish towel).
- Do not use abrasive or scouring agents.
- Any limescale deposits can be removed with a sponge and a vinegar-based cleaner or a limescale cleaner that is suitable for acrylic glass. When using limescale cleaners, dilute them properly and leave them on for only a short while, then rinse off with lots of water!



Aggressive chemicals and concentrated cleansing agents that are not diluted may damage the material if they are used incorrectly or left on too long. In addition, please observe the instructions given by the manufacturer of the household cleaner in question.

Accessories

Rules for upkeep

- Clean synthetic parts (i.e. bumpers, protective covers) with warm water (up to 60° C) and mild household cleaner.
- If necessary, grease door hinges and lifting stanchions.
- Clean the fresh water taps, fresh water tank and waste water tank annually.



Do not use scouring solvents since these could scratch the surface!



Remove all spray cans with cleaners and polishes from the vehicle after finishing the upkeep! Otherwise, there is a danger of explosion at temperatures over 50° C!

11.4 Winter operation

Preparation

Due to the overall vehicle conception, (aluminium sandwich construction with insulated windows) your caravan is suitable for winter operation.



We recommend that you optimise your caravan in accordance with your personal tastes for winter camping. Your dealer will gladly advise you in these matters.

Rules for preparation

- Examine the vehicle for damage to paint or through rust, and repair if necessary.

- Ensure that no water can seep into the forced de-aeration system in the floor or into the heating element.
- Protect the metal parts of the lower floor against rust with a wax-based protective agent.
- Preserve lacquered surfaces with a suitable agent.

Perform all necessary winterproofing

General rules

- Only leave the caravan in an enclosed space if this space is dry and well ventilated. Otherwise, park the caravan out in the open.

Rules for inner furnishings

- Empty and clean the refrigerator. Leave the refrigerator door open.
- Leave storage spaces and closets open for ventilation purposes.
- Position cushions and mattresses in such a way that they do not come into contact with condensation.
- If necessary, heat the entire caravan to prevent mould build-up from condensation moisture.
- Set up a dehumidifier inside the vehicle and dry or change the granulate material regularly.
- Disconnect (or ideally, remove) batteries and check the energy level at least once a month, recharging if necessary.
- Completely empty the entire water system.
- If the trailer is not used for a longer period of time or in winter storage, remove all aggressive food such as salt, vinegar, oils, or other spices from the trailer. In combination with high room air humidity, they can damage galvanised or metal surfaces (slide-bearing drawers, wire baskets, etc.).

Winter operation

In the course of winter operation, condensation forms at low temperatures when the vehicle is occupied. Sufficient ventilation plays a very significant role in ensuring a suitable air quality within the vehicle and preventing damage by condensation.

Rules for ventilation

- Set the heating element to the highest position and open ceiling barriers, curtains and shades while the vehicle is initially being heated. In doing this, you ensure optimum ventilation and de-aeration.
- Only operate the heating element when the air circulation unit is on.
- In the morning, remove all cushions, ventilate all storage compartments and dry moist spots.
- Install a chimney extension that is sufficiently long.



If condensation should build up somewhere in spite of these preventive measures, just wipe it away.



After strong snowfalls, always remove the snow from the roof to reduce the load, taking into account that powder snow weighs significantly less than settled snow, which holds a lot of moisture.

Frost protection measures

If the interior is sufficiently heated, it is unlikely that the fresh water tank, taps and warm water boiler would freeze. Only fill the fresh water tank after the vehicle has been heated. We do recommend, however, an additional heating element for the tank when exterior temperatures drop sharply. Your dealer will show you several possibilities. (Not included)

Rules for the waste water tank

- Add antifreeze or table salt to the waste water in low temperatures.
- Catch waste water outside the vehicle.
- Keep the spout of the waste water tank open.

After the end of the winter season

Rules for upkeep:

- Carry out a thorough undercarriage wash. This removes thawing agents (salts, lye residue).
- Clean the exterior of the caravan and use commercially available car wax to preserve steel parts.
- Should you have installed one, do not forget to remove the chimney extension.



Only wash the vehicle at specially designated sites.

Use cleaners as sparingly as possible. Aggressive cleaners (i.e., rim cleaner) pollute the environment.

Rules for the exterior structure

- Turn stanchions down. Wheels and axles must still carry the vehicle.
- Preserve painted exterior surfaces with a suitable material.
- Use a protective agent to protect the metal parts of the under carriage against rust.
- Cover with tarpaulins, ensuring that ventilation is not obstructed.
- Leave the forced ventilation system open.
- Air the caravan thoroughly every three to four weeks.

Rules for containers

- Empty and clean the fresh water tank with a pump, if necessary with a plunger.
- Empty and clean the waste water tank.
- Empty and clean the WC tank.
- Empty the hot-water boiler completely: switch off the 12 V power supply by means of the main switch on the control panel and open all of the water faucets. In addition, we recommend that you separate the water pump from the fresh water system.
- Ensure that no water can seep into the forced ventilation system in the floor and into the heating element.



Also note the guidelines and operating instructions from the manufacturers of all built-in devices.

12.1 The environment and mobile travel

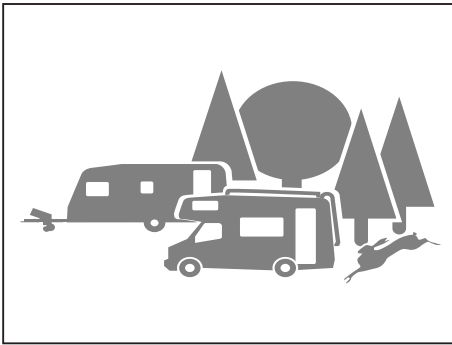

Environmentally sound use

By nature of their activities, caravan users bear a considerable responsibility towards the environment.

Therefore, you should always use your caravan in an environmentally sound manner.

Rules for environmentally sound use:

- Do not interfere with the quietude and cleanliness of nature.
- Dispose of waste water, faeces and trash properly.
- Act as a role model, so that caravans are not stereotyped as environmental polluters.
- If you plan to stay longer in cities and municipalities, please park in an area that is specifically marked for trailer combinations. Find out in advance where these areas are located.



Rules for waste water disposal:

- Only collect waste water in the built-in tanks or, if absolutely necessary, in similarly suitable containers!
- Never dispose of waste water in greenery or in gullies! Street sewer lines often do not lead to waste water treatment plants.
- Empty the waste water tank as often as possible, even if it is not yet full (for hygienic reasons). If possible, rinse the waste water tank out with fresh water each time after emptying.



Only empty the faeces tank at designated sites, never out in the open! Disposal stations are typically located at highway rest stops, campsites or service stations.



Rules for the disposal of faeces:

- Only add approved cleaners to the faeces tank.



Apply cleaning fluid very sparingly. Excessive application does not guarantee the prevention of odour build-up!

Disposal:

- Never allow the faeces tank to become too full. Empty the tank immediately, at the latest when the fill indicator lights up.
- Never dispose of waste water in gullies! Street sewer lines often do not lead to waste water treatment plants.



Only empty the faeces tank in the designated areas, not out in the open!

FENDT 12. Waste disposal and environmental protection

CARAVAN



Rules for trash disposal:

- Separate trash and bring recycleable materials to the appropriate collection sites.
- Empty trash containers in designated areas as often as possible. This prevents unpleasant odours and trash build-up.

Rules for rest areas:

- Always keep rest areas clean, even if the mess was created by others.
- Never dispose of your household trash in the containers provided in rest areas.
- Do not let the motor of your base vehicle run unnecessarily while standing still. A cold motor causes a lot of contamination while idling. The quickest way to reach operating temperature is while driving.



The preservation of the environment is not just in the best interests of nature, but also in the best interests of all caravans!



Further important information on the environment and waste disposal can be found in the additionally enclosed operating instructions of the device manufacturers included in the documents for your vehicle.

The methods for disposal recommended in these instructions must be met accordingly.

The applicable legal and official regulations at the place of disposal and the methods for disposal provided there must be taken into account when disposing of the trailer or its fixtures and fittings.

13.1 Tire pressure values

Tire size	Distinction	Air pressure in bar
175/70 R 14		3,0
185/65 R 14		3,0
195/65 R 14		3,0
195/65 R 15		3,0
205/60 R 15		3,0
195/65 R 15 LI 95	reinforced oder extraload	3,2
205/60 R 15 LI 95	reinforced oder extraload	3,2
205/65 R 15 LI 99	reinforced oder extraload	3,2
185 R 14 C		3,8
195 R 14 C		3,8
195/70 R 15 C		4,3
205 R 14 C		4,5
205/65 R 15 C		3,8
205/70 R 15 C		4,3
215/70 R 15 C		4,5
215/75 R 14 C		4,5
195/70 R 14 C		4,0



Please check the tire pressure regularly; always check it before moving the caravan. Insufficient tire pressure is the most frequent cause of tire damage.

We are not liable if this regulation is not observed!
Maximum speed: 100 km/h.

Observe the speed regulations of the country you are driving in!

On no account may the specified tire pressure be exceeded; not even if a higher value is stated on the tire wall.



As a rule of thumb, it may be assumed that a full tire loses 0.1 bar every two months. Check the pressure regularly to avoid damaged or bursting tires.

13.2 Technical data
APER0

	Length overall cm	Length of the super-structure cm	Effective length cm	Width overall cm	Height overall cm	Headroom cm	Technically permissible maximum weight* kg	Thickness of floor/ceiling/wall mm	Tires**
465 SFB	703	589	507	232	266	198	1500	47 / 39 / 31	205/65 R 15
465 TG	703	589	507	232	266	198	1500	47 / 39 / 31	205/65 R 15
495 SFB	722	607	526	232	266	198	1600/1700	47 / 39 / 31	195/70 R 15 C
495 Connect	722	607	526	232	266	198	1800	47 / 39 / 31	205/70 R 15 C
495 SG	722	607	526	232	266	198	1600/1700	47 / 39 / 31	195/70 R 15 C
495 SKM	722	607	526	232	266	198	1600/1700	47 / 39 / 31	195/70 R 15 C
515 SG	751	637	556	232	266	198	1600/1700	47 / 39 / 31	195/70 R 15 C
560 SKM	772	657	576	250	266	198	1700	47 / 39 / 31	195/70 R 15 C

BIANCO SELECTION

	Length overall cm	Length of the super-structure cm	Effective length cm	Width overall cm	Height overall cm	Headroom cm	Technically permissible maximum weight* kg	Thickness of floor/ceiling/wall mm	Tires**
465 SFB	703	589	507	232	266	198	1500	47 / 39 / 31	205/65 R 15
465 TG	703	589	507	232	266	198	1500	47 / 39 / 31	205/65 R 15
515 SG	751	637	556	232	266	198	1600/1700	47 / 39 / 31	195/70 R 15 C
515 SKM	751	637	556	232	266	198	1600/1700	47 / 39 / 31	195/70 R 15 C
550 SKM	772	657	576	232	266	198	1700	47 / 39 / 31	195/70 R 15 C

BIANCO ACTIV

	Length overall cm	Length of the super-structure cm	Effective length cm	Width overall cm	Height overall cm	Headroom cm	Technically permissible maximum weight* kg	Thickness of floor/ceiling/wall mm	Tires**
390 FHS	603	488	407	232	266	198	1500	47 / 39 / 31	205/65 R 15
445 SFB	677	562	481	232	266	198	1500	47 / 39 / 31	205/65 R 15
465 SFH	703	589	507	232	266	198	1600/1700	47 / 39 / 31	195/75 R 15 C
465 SGE	703	589	507	232	266	198	1600/1700	47 / 39 / 31	195/70 R 15 C
495 SFE	722	607	526	232	266	198	1700	47 / 39 / 31	195/70 R 15 C
515 SGD	751	637	556	232	266	198	1700	47 / 39 / 31	195/70 R 15 C
515 SGE	751	637	556	232	266	198	1700	47 / 39 / 31	195/70 R 15 C
515 SKF	751	637	556	232	266	198	1700	47 / 39 / 31	195/70 R 15 C
550 KMG	772	657	576	232	266	198	1700	47 / 39 / 31	195/70 R 15 C
550 SD	772	657	576	232	266	198	1700	47 / 39 / 31	195/70 R 15 C
560 SKM	772	657	576	250	266	198	1700	47 / 39 / 31	195/70 R 15 C

13. Technical data

TENDENZA

	Length overall cm	Length of the super-structure cm	Effective length cm	Width overall cm	Height overall cm	Headroom cm	Technically permissible maximum weight* kg	Thickness of floor/ceiling/wall mm	Tires**
465 SFB	703	589	507	232	266	198	1500	47 / 39 / 31	205/65 R 15
515 SG	751	637	556	232	266	198	1700	47 / 39 / 31	195/70 R 15 C
550 SG	772	657	576	232	266	198	1700	47 / 39 / 31	195/70 R 15 C
560 SFDW	772	657	576	250	266	198	1800	47 / 39 / 31	205/70 R 15 C
560 SG	772	657	576	250	266	198	1800	47 / 39 / 31	205/70 R 15 C
650 SFD	855	741	659	250	265	198	2000	47 / 39 / 31	185/65 R 14

DIAMANT

	Length overall cm	Length of the super-structure cm	Effective length cm	Width overall cm	Height overall cm	Headroom cm	Technically permissible maximum weight* kg	Thickness of floor/ceiling/wall mm	Tires**
560 DW	771	656	563	250	266	198	1900/2000	47 / 39 / 31	215/70 R 15 C
560 SGW	771	656	563	250	266	198	1900/2000	47 / 39 / 31	215/70 R 15 C
650 GDW	860	746	654	250	265	198	2200	47 / 39 / 31	195/65 R 15

VIENNA

	Length overall cm	Length of the super-structure cm	Effective length cm	Width overall cm	Height overall cm	Head-room cm	Technically permissible maximum weight* kg	Thickness of floor/ceiling/wall mm	Tires**	Measurements of Outer Tent Perimeter cm
650 SMF-UK	855	741	659	250	265	198	2200	47 / 39 / 31	195/65 R 15	1117
700 SFD-UK	896	782	700	250	265	198	2200	47 / 39 / 31	195/65 R 15	1158

Legend

The masses for caravans are calculated on the basis of Directive (EU) No. 1230/2012.

* for increased and reduced loads

** These tires correspond to the standard tyres. However, for organizational and logistical reasons, your vehicle may be fitted with alternative tires. Please refer to Motor Vehicle Registration Certificate Part II or the EU Certificate of Conformity (CoC) for information regarding permissible wheel/tire combinations.



For further technical data as well as information on masses and measurements of your Fendt caravan, please refer to the EU Declaration of Conformity / Certificate of Conformity (COC), the Motor Vehicle Registration Certificate or the technical data sheet.

13.3 Measurements of Outer Tent Perimeter

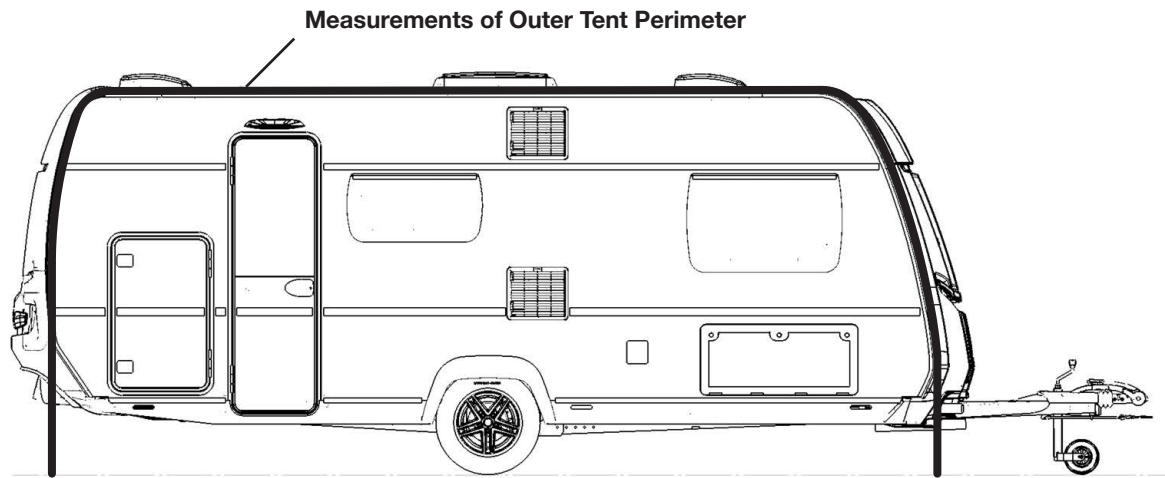

This measurement diagram applies for all camper models. The vehicle must be standing parallel to the ground.

Height of the outer tent guide rail:
Single axle approx. 2.49 - 2.54 m (8.17 - 8.33 ft.)
Tandem axle approx. 2.49 - 2.55 m (8.17 - 8.37 ft.)

The outer tent guide rail is designed for a standard outer tent keder with a diameter of 7-8 mm.

Tolerance of length dimensions: +/- 0.5%

APER0

		1.500 kg	1.600 kg	1.700 kg	1.800 kg	1.900 kg	2.000 kg	2.200 kg	2.400 kg	2.500 kg	2.800 kg
465 SFB/TG	cm	962	969	969	966	-	-	-	-	-	-
495 SFB/SKM/SG/Connect	cm	-	982	982	985	987	987	-	-	-	-
515 SG	cm	-	1017	1017	1015	1019	1019	-	-	-	-
560 SKM	cm	-	-	1029	1034	1039	1039	-	-	-	-

BIANCO SELECTION

		1.500 kg	1.600 kg	1.700 kg	1.800 kg	1.900 kg	2.000 kg	2.200 kg	2.400 kg	2.500 kg	2.800 kg
465 SFB/TG	cm	962	969	969	966	-	-	-	-	-	-
515 SG/SKM	cm	-	1017	1017	1015	1019	1019	-	-	-	-
550 SKM	cm	-	1030	1030	1030	1039	1039	-	-	-	-

BIANCO ACTIV

		1.500 kg	1.600 kg	1.700 kg	1.800 kg	1.900 kg	2.000 kg	2.200 kg	2.400 kg	2.500 kg	2.800 kg
390 FHS	cm	864	866	866	-	-	-	-	-	-	-
445 SFB	cm	934	940	940	-	-	-	-	-	-	-
465 SFH /SGE	cm	-	969	969	966	-	-	-	-	-	-
495 SFE	cm	-	-	982	985	987	987	-	-	-	-
515 SGD/SGE/SKF	cm	-	-	1017	1015	1019	1019	-	-	-	-
550 KMG/SD	cm	-	-	1030	1030	1039	1039	-	-	-	-
560 SKM	cm	-	-	1029	1034	1039	1039	-	-	-	-

13. Technical data

TENDENZA

		1.500 kg	1.600 kg	1.700 kg	1.800 kg	1.900 kg	2.000 kg	2.200 kg	2.400 kg	2.500 kg	2.800 kg
465 SFB	cm	962	969	969	966	-	-	-	-	-	-
515 SG	cm	-	-	1017	1015	1019	1019	-	-	-	-
550 SG	cm	-	-	1030	1030	1039	1039	-	-	-	-
560 SG/SFDW	cm	-	-	-	1034	1039	1039	-	-	-	-
650 SFD	cm	-	-	-	-	-	1119	1126	1126	1126	1126

DIAMANT

		1.500 kg	1.600 kg	1.700 kg	1.800 kg	1.900 kg	2.000 kg	2.200 kg	2.400 kg	2.500 kg	2.800 kg
560 DW/SGW	cm	-	-	-	-	1027	1027	-	-	-	-
650 GDW	cm	-	-	-	-	-	-	1116	1116	1116	1116

13.4 Basic equipment

For fresh water tank, 25 l

Position	Weight (kg)	Number	Total (kg)
Aluminium gas bottle, empty	6	1	6
Gas filling	11	1	11
Hot water heater (Truma ^{**})	5	1	5
Fresh water tank filled for driving	10	1	10
Fresh water for toilet, C500 [*]	16	1	16
			48

For fresh water tank, 45 l

Position	Weight (kg)	Number	Total (kg)
Aluminium gas bottle, empty	6	1	6
Gas filling	11	1	11
Hot water heater (Truma-Therme ^{**/**})	5	1	5
Fresh water tank filled for driving	10	1	10
Fresh water for toilet, C500 [*]	16	1	16
			48

* Toilet alternative: fresh water for toilet, C262	8	1	8
---	---	---	---

** Hot water supply, alternative: Truma heating Combi C4 / C6E	10	1	10
---	----	---	----

*** alternative hot-water heater: ALDE hot-water heater C 3030	10	1	10
---	----	---	----



The calculation of mass for the basic equipment may change if you install special accessories. Your Fendt caravan dealer will be pleased to provide you with competent advice if you have more detailed questions.

13. Technical data

13.5 Lighting (APER0, BIANCO, TENDENZA, PALACE)

12 V Vehicle lighting			
Position	Description	Voltage	Watt
1	Brake light, top	12	LED
2	Clearance lights, rear	12	LED
3	Side/driving light, left	12	LED
4	Side/driving light, right	12	LED
5	Left blinker	12	LED
6	Right blinker	12	LED
7	Left reverse light	12	LED
8	Right reverse light	12	LED
9	Left brake light	12	LED
10	Right brake light	12	LED
11	Fog tail light	12	LED
12	Registration plate light	12	LED
13	Clearance lights, front	12	LED
14	Running lights, front	12	LED
15	Side marker lights	12	LED

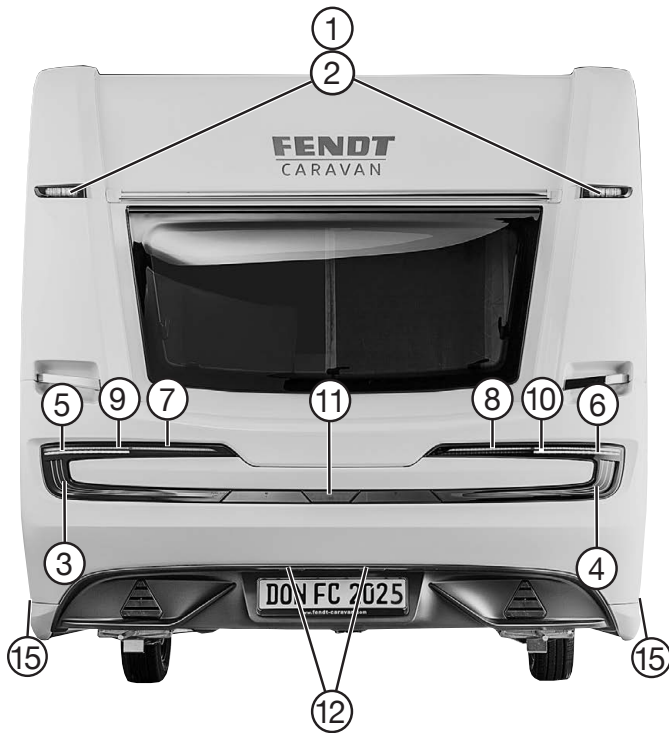

Lighting (DIAMANT)

12 V Vehicle lighting			
Position	Description	Voltage	Watt
1	Brake light, top	12	LED
2	Clearance lights, rear	12	LED
3	Side/driving light, left	12	LED
4	Side/driving light, right	12	LED
5	Left blinker	12	LED
6	Right blinker	12	LED
7	Left reverse light	12	LED
8	Right reverse light	12	LED
9	Left brake light	12	LED
10	Right brake light	12	LED
11	Fog tail light	12	LED
12	Registration plate light	12	LED
13	Clearance lights, front	12	LED
14	Running lights, front	12	LED
15	Side marker lights	12	LED

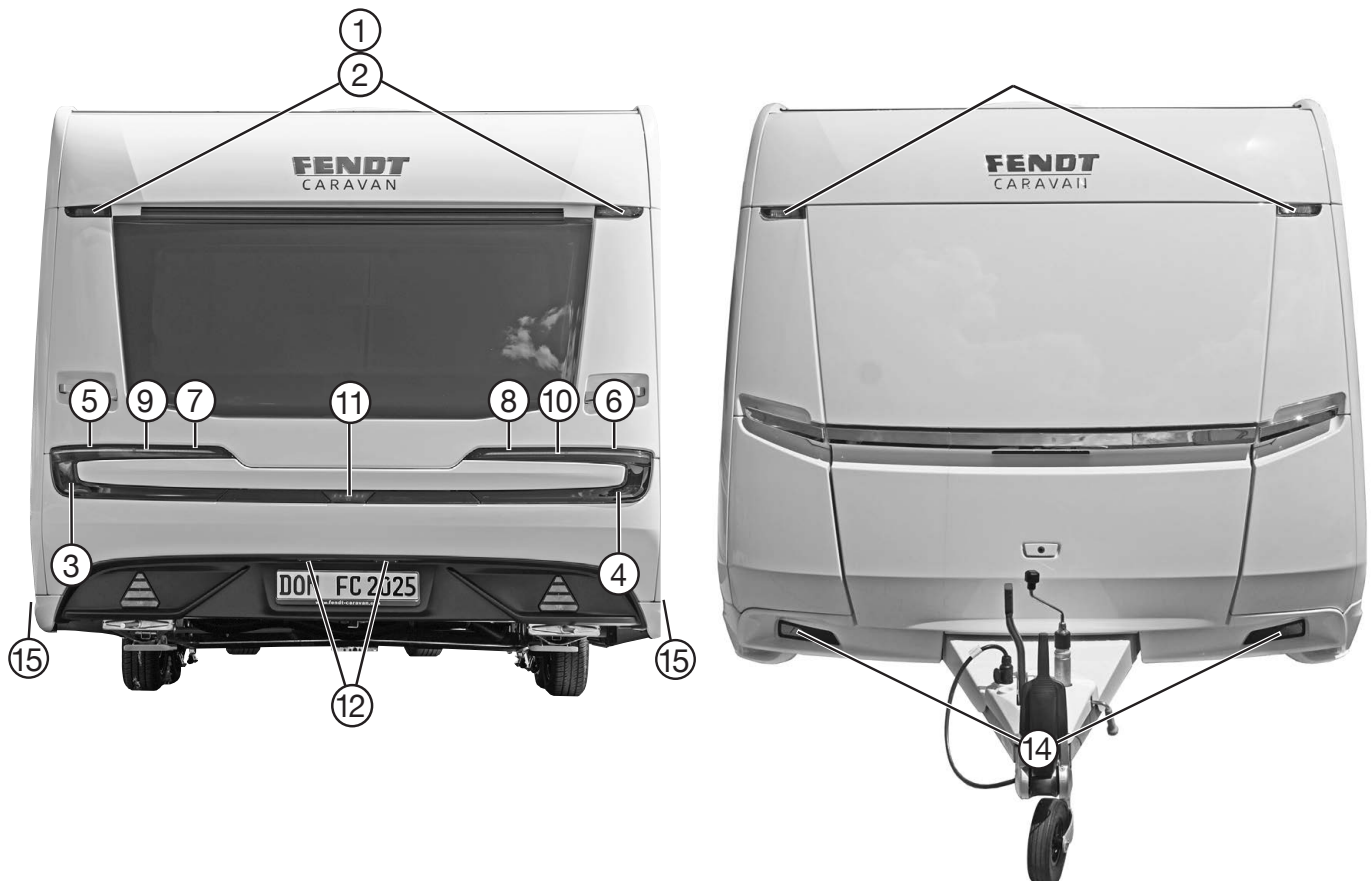

Replacing the lamps in the rear lights



In full LED lights, it is not possible to change individual bulbs.

Index**A**

Accessories 94
Additional equipment 18
Additional loads 6, 17
Air-circulation fan 88
Airing 96
Automatic igniter 87
 changing the battery 87
Awning installation 32

B

Basic equipment 18, 113
Bed conversion 33
Bicycle carrier 31
Brakes 8, 13
Bunk beds 38

C

Changing the tyre 22
Checking the gas system 83
Choosing a parking space 9
Circuit diagram, lighting of the vehicle 71
Control panel 45
Corner steadies 15

D

Definition of masses 17
Doors
 opening and closing 33
Drawbar load 7
Driving 8
Driving in curves 8
Driving in reverse 9
Driving noises 12

E

Electric power supply 41
 Safety tips 41
Electrical devices
 redirecting 10
Electrical floor temperature control system 74
Emergency equipment 3
Entrance door 25
Environmental protection 106

F

Fendt Caravan Connect 53
Fighting a fire 3
First aid kit 3
Forced ventilation 24
Fresh water tank 79

G

Gas 83
Gas box 85
Gas container flap 30

Gas hob 93
Gas supply 85
Gas system
 inspection 83
General inspection 16
Greasing 11, 95
Guide rail for outer tent 31

H

Hand brake 13
Heating 25, 59, 86
High-visibility vest 3
Hot-air heating 86
Hot-water heater 88
Hot-water supply 79

K

Keys to the vehicle 3

L

Lighting 57, 114
Loading 6
Lockers
 opening and closing 33

M

Maintenance 11, 91, 95
Mass, definition 17

O

Oiling 11, 95
Oven 93
Overrunning brake facility 8

P

Push lock 33

R

Refrigerator 24, 91
Registration 16
Regulator knobs 83
Rims 20
Roof rail 32

S

Safety coupling 12
Securing the vehicle 10
Service lockers 29
Shunting 9
Shutoff valves
 place of installation 86
Suitability for a speed of 100 km/h 16

T

Technical data
 tyre pressure 108

Technically permissible maximum weight 17
Toilet cassette access door 30
Truma therme 79
Tyre pressure 19, 108
Tyre profile depth 20
Tyres 19
Tyres, age of 20

U

Undercarriage 100
Upkeep 97

V

Valves 86
Ventilation and de-aerating 24, 96

W

Warning triangle 3
Waste water tank 78
Water supply 78
Water system 10
Windows 40
 upkeep 98
Winter operation 103

Fendt-Caravan GmbH
Postfach 11 35
86689 Mertingen
Deutschland

Telefon: +49 (0)9078.9688-0
Telefax: +49 (0)9078.9688-406

www.fendt-caravan.com